

CENTER FOR ACOUSTICS AND VIBRATION

Newsletter 2020



Note from the director

Welcome to our new and improved CAV newsletter! Thanks to our College of Engineering communications team, we've got a great new look and feel. All the usual content is here, including updates from our technical groups, graduating students, honors and awards, and other highlights. We have more feature articles this year, including Micah Shepherd's work with Martin Guitar Company (a CAV sponsor), and a nice focus on Molly Smallcomb, one of our graduate students. We're sad to see our longtime colleague Marty Trethewey retire. We're excited, however, to welcome a new Penn State center with ties to the CAV—the Penn State Center for Gas Turbine Research, Education, and Outreach, headed by Jackie O'Connor.

We have all had to adapt to the challenges caused by the COVID-19 virus. The CAV had to cancel most of our spring seminars. However, you can still watch previously recorded seminars at www.cav.psu.edu/seminars.aspx. We are planning a few online summer seminars by CAV faculty—look for announcements via email soon. Finally, we are still planning on holding the annual CAV workshop Oct. 27-28 as scheduled, but anticipate a "mixed" event, where we will broadcast the talks via Zoom for those who are unable to travel to Penn State. In the event Penn State continues its distancing policies into the fall semester, we will revert to a fully virtual workshop. Either way, plan on catching up with the CAV Oct. 27-28 in some fashion!

Thanks to our sponsors for their continued support, and to our members for continuing to make the Penn State Center for Acoustics and Vibration a world leader in our field.

– Steve Hambric // sah19@psu.edu

Contents

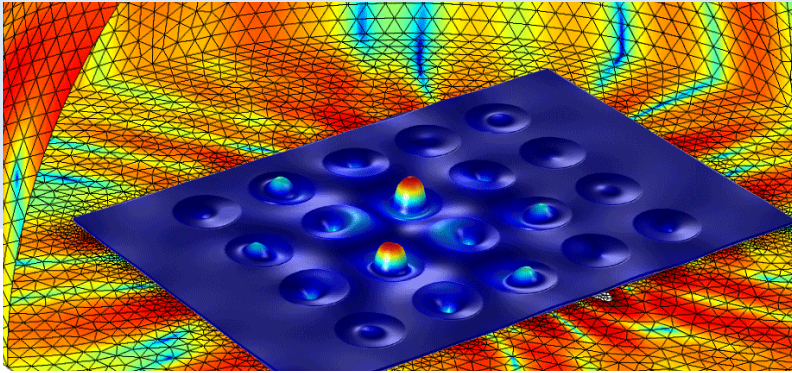

Featured Stories

2

That Martin Sound

6

Penn State Center for Gas Turbine Research, Education, and Outreach founded with close ties to CAV

7

Penn State acoustics program strikes right tone with doctoral student

10

Penn State's Martin Trethewey retires

Table of Contents

- 4** Annual CAV Workshop
- 5** CAV Seminars Info
- 11** New Faculty Biographies
- 14** International, Government, and Vendor Liaisons
- 15** CAV Member Student Honors and Awards
- 17** CAV Graduate Student Theses
- 18** Penn State Graduate Program in Acoustics Distance Education Course
- 20** Technical Research Group Highlights
- 71** Contact

That Martin Sound

Penn State's world-class acoustics expertise aids a legendary Pennsylvania company

by Dave Pacchioli and Emily Kissinger

Acoustics has long been an area of strength at Penn State. Expertise in acoustics is a core competency of the University's Applied Research Laboratory (ARL), one of the top defense-related research labs in the nation. The College of Engineering's Graduate Program in Acoustics dates to 1965 and remains the only program in the U.S. that offers a doctorate in the subject. The interdisciplinary Center for Acoustics and Vibration fosters partnerships with industry, bringing all that expertise to bear on practical problems.

Micah Shepherd, assistant research professor of acoustics, and a team of Penn State acoustics experts worked with Martin Guitar to develop a method to analyze acoustic properties of guitars and components—to understand the science behind the variance in sound produced by different guitars and guitar components.

Balancing tradition and innovation

C.F. Martin & Co.[®], the family-owned guitar maker in Nazareth, Pennsylvania, has been making acoustic instruments since the 1830s and has always relied on a balance of tradition and innovation to remain the most sought-after acoustic guitar brand in the world.

Partnering with Penn State is one example of the ways in which Martin continues to innovate.

After ARL's Dave Swanson, an avid guitar player as well as an acoustical engineer, toured the Martin factory a few years ago, he approached Martin representatives to show them how Penn State could help Martin bring a scientific approach to evaluating the sound of its guitars.

"They have talented musicians who listen to and score guitars on certain metrics—based purely on the sound," Shepherd said. "What we could offer was a supplement to their current evaluation process—a tool that provides quantitative data that allows them to evaluate whole guitars, as well as guitar components."

Intrigued, Martin representatives brought several of their high-end guitars to ARL's anechoic chamber, a cavernous sound-dampened room. There, Shepherd and others wired the instruments with shakers and sensors, buzzed them with white noise, and rapped them with force hammers, carefully measuring the ensuing vibrations. The data they collected established a "vibro-acoustic fingerprint" for each guitar.

"We're interested in understanding the dynamic properties of both finished instruments and raw materials, and how that affects tonal qualities," said Josh Parker, a Penn State alumnus and research and development technician at Martin.

The science of sound

"These real-world applications of our research serve as a win-win for us as faculty members, our students, and our business and industry partners," Shepherd said. The project—applying Penn State research in a practical setting for an industry partner—fit perfectly with the outreach mission of the Center for Acoustics and Vibration.

For Shepherd and his colleagues, working with musical instruments presented new challenges. Most of the center's corporate partners, he explained, are looking for ways to minimize vibration.



“We’re interested in understanding the dynamic properties of both finished instruments and raw materials, and how that affects tonal qualities.”

In the case of a guitar, however, vibration is a good thing—and Martin guitars, in particular, are famous for their resonance. In part, it is traced to the types of wood Martin has traditionally used: Sitka spruce for the top and rosewood for the sides and back. But, as a leader in environmental stewardship, the company understands the scarcity of these precious tonewoods and is always in search of sustainable alternatives. The trick, Parker said, is to find a combination that can match that classic sound.

“How you cut the wood, the grain, the moisture content, all of these things have to be accounted for,” Shepherd said. “They all affect the amount of vibration.”

“No two pieces of wood are exactly the same, which means no two guitars sound exactly the same,” Parker said. To complicate things even more, a guitar is what engineers call “a coupled system.” A change in any one of its interconnected components will impact the whole.

A complement to craft

After the initial evaluations at ARL, Shepherd and his colleagues put together a system to enable Martin’s sound engineers to continue testing on their own. That meant recommending the necessary equipment, advising on the set-up of a mini-anechoic chamber at the factory in Nazareth, and developing the custom software Martin would need to collect and process vibration data. Parker has been using the system ever since, not to replace the old qualitative approach, but to complement it. Modal analysis has allowed him to compare Martin’s current line to competitors’ guitars and to the vintage instruments displayed in the company’s museum. Dating to the 1930s, these Pre-war Martins, as they are known, “are really that quintessential Martin sound,” Parker said. “This technology can help us as we try to replicate elements of that.”

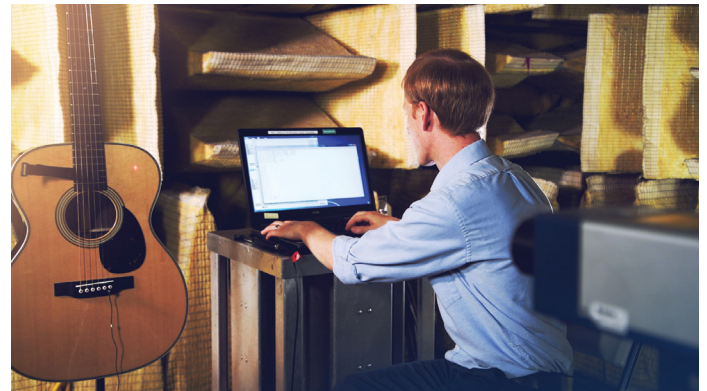

Micah Shepherd in the anechoic chamber demonstrating the testing used to determine the vibro-acoustics fingerprint for a Martin Guitar.

He is also testing individual components, measuring the effect of substituting a mahogany top for spruce, say, or altering the shape of an internal brace. Soon he plans to start evaluating raw materials. The database he’s building, he hopes, will help guide design decisions as Martin adapts to changing circumstances.

“Eventually, the idea is to be able to accurately model guitars on the computer,” Parker said. And while both he and Shepherd know that a computer model will never replace the knowledge accrued over two centuries of craftsmanship, “It’s fun to think about how this kind of innovation can help move our design into the future,” he said. “It’s actually kind of mind-blowing when you consider all the possibilities.”

C.F. Martin & Co. is a corporate sponsor of Penn State’s Center for Acoustics and Vibration.

Annual CAV Workshop

October 27–28, 2020



The annual CAV Workshop, currently planned for Oct. 27–28, 2020, is a two-day event held at Penn State University Park for our corporate sponsors, international liaisons, U.S. government liaisons, and Penn State CAV faculty and students. The workshop is free to all CAV members and is a mix of technical presentations, lab tours, and social activities. The workshop also gives our visitors an opportunity to meet and recruit our graduate students.

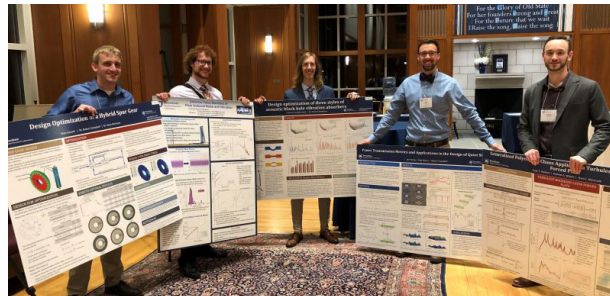

2019 Evening social at the Penn State Hinz Alumni Center

2019 Student Poster Competition competitors

This year's events will include:

- Two days of technical presentations and discussions.
- A graduate student technical poster competition (Oct. 27, 6:30–8:30 p.m. in the Hinz Alumni Center): Our corporate sponsors, government guests, and international liaisons will judge the posters. Three \$1,000 prizes will be awarded to support travel costs for students presenting their work at upcoming conferences. Last year's winners were Molly Smallcomb, Eric Rokni, and Gage Walters.
- In previous years, the CAV workshop has been followed immediately by a one-day technical short course. Since we are uncertain about what travel restrictions will be in place this October, the short course topic and format remain open. We will notify our members when plans are confirmed.
- This year, we are planning to include an online component so those unable to travel can experience the workshop. In the event Penn State continues its restrictions on in-person events due to COVID-19, we will shift to a fully online workshop.

CAV Seminars Information

CAV members may access our previous lunchtime seminar series online. Videos of the presentations from fall 2009 to present may be viewed. This is a service to our members only, so please contact Steve Hambric at sah19@arl.psu.edu for the site location.

Spring 2020

| SPEAKER | AFFILIATION | DATE | SEMINAR TOPIC |
|-------------------------|-----------------------------------|-------------|--|
| Vamshi Krishna Chillara | Los Alamos National Lab | February 19 | Acoustic Collimated Beam (ACCObeam) Source for Imaging through Attenuating Materials: Application to Borehole Integrity Monitoring |
| Jennifer Cooper | Johns Hopkins Applied Physics Lab | February 6 | Impact of Salinity on Predicted Transmission Loss and Predicting Errors through Machine Learning |

Fall 2019

| | | | |
|-------------------------|---------------------------|-------------|--|
| Tim Brungart | Penn State | December 6 | The Control of Quadcopter Propeller Noise |
| Xin Ying | Penn State | December 4 | Manufacturing, Materials, and Mechanics of Flexible Electronics for Highly Deformable Structures |
| Chris Kube | Penn State | November 18 | Advancing the Science of Metallic Additive Manufacturing through Ultrasonic Characterization of Laser-generated Melt Pools |
| Kostas Papakonstantinou | Penn State | November 13 | Optimum Life-Cycle Policies and Value of Structural Monitoring Quantification with POMDPs and Deep Reinforcement Learning |
| Omer Oralkan | NC State | November 4 | Capacitive Micromachined Ultrasonic Transducers on Glass Substrates for Imaging, Sensing, and Therapy |
| Ying-Tsong Lin | Woods Hole | October 28 | Three-Dimensional Shallow Water Acoustics |
| Michael Bianco | UC San Diego | October 23 | Introduction to Machine Learning in Acoustics: Theory and Applications |
| Eric Bechoefer | GPMS, Inc. | October 21 | Health and Usage Monitoring Systems Return on Investment: Making the Business Case for HUMS |
| Huageng Luo | Xianmen University, China | October 4 | Physics-based Data Analytics and its Application in Wind Turbine Condition Monitoring |



Penn State Center for Gas Turbine Research, Education, and Outreach founded with close ties to CAV

Penn State's Center for Gas Turbine Research, Education, and Outreach was approved in Feb. 2020 with CAV member Jacqueline O'Connor appointed as its director. The [center](#) is based on the broad range of expertise of our faculty, existing strong partnerships with industry and government, and the desire to be at the forefront of emerging trends in aviation, power generation, and industrial sectors where gas turbines are of prime importance. These advances require focused research efforts, development of a highly trained workforce, and engagement with policymakers, industry leaders, and gas turbine users to ensure impact.

Penn State has over 30 faculty working on technologies relevant to gas turbines, with more than \$13 million in relevant research expenditures over the past five years. In particular, Penn State excels in executing multi-disciplinary research with several industrial and federal projects that span departments and colleges.

The University also provides unique educational opportunities in state-of-the-art classes as well as novel delivery platforms (online courses, industry-delivered workshops). There are more than 40 courses offered in areas relevant to gas turbines, many of which are online via Penn State's World Campus in both undergraduate and graduate degree programs.

Penn State faculty hold a number of strategic leadership positions on technical committees, leadership boards, and editorial positions within professional societies—including the American Society of Mechanical Engineering's Gas Turbine Segment, the American Institute of Aeronautics and Astronautics, and ASM International. This center will have close ties to the Center for Acoustics and Vibration given the gas turbine's interest in a number of challenging acoustic phenomena, including aeroelastic vibration in turbomachinery, jet noise, thermoacoustic oscillations, ultrasonic testing, and many more. [LEARN MORE >>](#)



Molly Smallcomb is a third-year doctoral student in Penn State's Graduate Program in Acoustics. Following her graduate studies, Smallcomb is interested in pursuing a career in academia.

Penn State acoustics program strikes right tone with doctoral student

When Molly Smallcomb was an undergraduate student at the University of Hartford, little did she know that her decision to attend a summer research program at Penn State would have such a profound impact on her future.

At the suggestion of her undergraduate adviser, a Penn State acoustics graduate, she took part in a Research Experience for Undergraduates program in acoustics at the University, an opportunity that altered her plans for life after college and set her on a path to pursue an advanced degree in the field.

Based on her meaningful undergraduate research experience, together with the fact that Penn State is the only institution in the United States that currently offers a doctorate in acoustics, University Park was Smallcomb's clear-cut top destination for graduate school.

With world-class faculty experts, robust industry connections and partnerships, a flexible and interdisciplinary curriculum, hands-on research opportunities, and a vibrant alumni network, Penn State's Graduate Program in Acoustics, housed in the College of Engineering, has long been an area of strength for the University.

Now in her third of year of graduate study, we sat down with Smallcomb to talk about her personal experiences in the program, and to learn about her research with therapeutic ultrasound in the Biomedical Acoustics Simon Lab (BASiL).

Q: What was the spark that fueled your interest in acoustics?

When I was in high school, I took my first physics class, and there was a week on sound. I was also really into music at the time. Just learning about the science of sound with that passion for music led me to try to find a degree that would marry the two, which I did at the University of Hartford in Connecticut, where I earned my bachelor's degree in acoustical engineering and music. My adviser there was a Penn State alum in the acoustics program, so that definitely helped.

Q: Before enrolling in Penn State's Graduate Program in Acoustics, you participated in the Research Experience for Undergraduates program at the University, where you were an undergraduate research assistant in the Sound Perception and Room Acoustics Laboratory (SPRAL). How did that opportunity come about, and how did it impact you personally?

It totally shifted my mindset. I was thinking about going into consulting at the time—acoustics consulting and architecture—and my adviser at the University of Hartford led me to apply for the REU program in acoustics. I came here and worked with Dr. Michelle Vigeant in SPRAL, and it completely changed my mind about graduate school and just wanting to further my knowledge in acoustics. It definitely led me on the path to graduate school rather than just going into industry.

Q: What did you learn from that undergraduate research experience and what type of work did you do?

During the summer I got to work with a graduate student who was doing concert hall acoustics, and I helped him build an audio system. It was a loudspeaker array where you could individually control each channel, allowing you to replicate any instrument that you wanted. When you're trying to do concert hall measurements, common practice is to use an omnidirectional loudspeaker, which doesn't completely replicate what an orchestra would be like. So the goal was to make a loudspeaker that could replicate an entire orchestra to get accurate concert hall measurements.

Q: Why did you choose Penn State? What sets Penn State's acoustics program apart?

Penn State was at the top of my list. The acoustics program has such a great reputation and network



that's been built over the years. In my opinion, compared to other schools I was looking at, Penn State's program has the best grasp of fundamental acoustics. Because students come from different backgrounds, the program spends the first year on very fundamental topics, so everyone is on the same page and everyone understands the broad basics of acoustics, which I really appreciated.

Another thing I appreciate about the program is that they haven't just focused on one field of study in acoustics. They like to keep it broad with the classes and with faculty who have expertise in a lot of different areas, where in another school you would see more of a focus on oceanography acoustics or architectural acoustics, for example. I think that's what sets Penn State apart.

The other thing of course would be how the program is the only one in the U.S. to have a Ph.D. in acoustics, which was huge for me because I wanted the general acoustics degree. Instead of being in a mechanical engineering program and concentrating on acoustics, we are in the heart of the field.

Q: Penn State's acoustics faculty have industry connections and use their expertise to solve practical problems, such as Assistant Research Professor of Acoustics Micah Shepherd's work with Martin Guitar. What real-world examples and case studies have faculty brought into the classroom to enrich your studies?

Dr. Shepherd was my professor for a lab class, and we did a modal analysis on a guitar where we learned how to measure the mode shapes of a guitar face, which was really interesting. That was probably my favorite lab study in that class.

Researchers in the Biomedical Acoustics Simon Lab at Penn State are studying therapeutic applications of ultrasound. Here, graduate student Molly Smallcomb is preparing a specimen in a water tank to see if focused ultrasound can create mechanical damage in connective tissue—and, ultimately, facilitate better healing for tendon injuries.

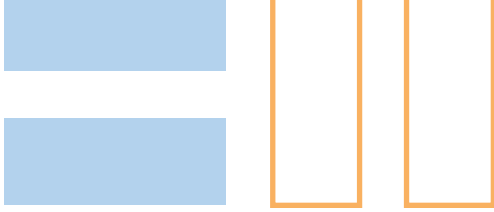

I liked that class because it gave us a lot of studies that were completely different from each other, and it provided a way to get research experience in an array of fields in a short amount of time. There was one lab on how to measure the characteristics of a loudspeaker, for example. There also was a study on how to characterize the acoustic implementation of construction at the IM Building. I definitely got a broad sense of acoustics and more practical applications than a normal class would be able to provide.

Q: What are your plans after you earn your doctoral degree? How has Penn State helped to shape your career path?

I want to get into some type of academic career pathway. Getting a teaching job would be my first plan, but I've also been interested in possibly going into outreach. We have the ASA (Acoustical Society of America) Club in our program, and I'm the club's outreach coordinator, so that's really inspired me to do more STEM outreach to younger kids and get them interested in the field. Especially being a woman in STEM, just being that role model for younger girls, to help influence them, is important to me. So that's another academic career I've considered, and the fact that the program has provided me with the opportunity to be in charge of that has been really nice.

Outside of the acoustics program, this past summer I was part of the Upward Bound Program. They had a summer program for potential first-generation students going to college, and I taught them geometry, which was really fun. It was my first teaching experience, and it really helped me understand if I could be a teacher and was capable of it. That was a really cool experience that was provided by Penn State.

“Our work involves therapeutic applications of ultrasound, specifically using focused ultrasound for tendon injuries.”

Q: In addition to teaching, what are some other career paths that students in the program follow?

There are a number of areas that you can go into. More recently, there's been a big shift to going into transducer design at companies like Apple or Bose. A big thing about our program is that since we have such a great network, companies often come here to recruit us rather than us going to them.

With the Applied Research Lab, there are government funding options. You can work on vibrational studies, which includes aerospace and structural design, such as with car companies. Then there's architectural or civil engineering. Consulting is a big field in acoustics, too, being the acoustics expert for architectural

or general engineering firms to design concert halls, modifying classrooms or conference rooms for a quieter space, or even implementing quiet HVAC equipment.

Q: You worked in SPRAL lab and now you're in the BASiL lab. When you came to Penn State, did you have a set idea of what you wanted to study in acoustics, and has that changed over time?

Coming into the program I had no idea what I wanted to study. Dr. Julianna Simon reached out to me and sold me on biomedical acoustics because it was so different than my undergrad and from my research in SPRAL. She motivated me to help widen my knowledge of acoustics and make me a better candidate for teaching.

Q: Can you describe your current research in BASiL?

Our work involves therapeutic applications of ultrasound, specifically using focused ultrasound for tendon injuries. Focused ultrasound is being used clinically, and the big question I'm trying to answer is whether mechanical damage is possible in connective tissue. Because the tendon is collagenous and fibrous, it doesn't really like to be broken up, probably for a reason. The overall application of this is similar to when you make microtears in your muscle to help build the muscle and make it stronger—I'm trying to make that microdamage in the tendon to break up scar tissue and help facilitate better healing. We're in collaborative efforts with Dr. Meghan Vidt and her lab, MUSL (Movement of the Upper Limb and Shoulder Lab), to address these issues.

Q: What is the potential impact of your work?

Current therapy methods have mixed success rates and can be invasive. With focused ultrasound, the big improvement is it's completely noninvasive, so you're never entering the body, and there are a lot of different parameters you can control. We still have to prove it to be successful, of course. So it could be a good therapy for tendon injury and other collagenous tissues. Obviously, it could help athletes, but it could help anyone who has developed chronic tendon injury from recreational sport or just age, too.

Q: Will you be following up to see if focused ultrasound can heal and strengthen tendons?

Yes, once the proof of concept is established and our parameter space is defined, then we would go to a live tissue and see if we can heal tendons. Dr. Simon and Dr. Vidt just received a National Institutes of Health grant, and I just got a National Science Foundation Graduate Research Fellowship Program grant, which is funding my next three years, so our plan is to continue this work and see if it's possible to heal tendons.



Penn State's Martin Trethewey retires

After contributing many years of service to Penn State, Martin Trethewey will retire in July 2020. Over the years, Trethewey held numerous positions at Penn State, but most recently served as a professor of mechanical engineering and professor of acoustics in the Graduate Program in Acoustics. His previously held positions include associate department head for undergraduate programs in the Department of Mechanical Engineering and Arthur L. Glenn Professor of Mechanical Engineering.

Trethewey was also the director of the Penn State Global Engagement Network, where he led the development of the University's international collaborations with numerous universities, including University of Freiburg, Germany; University of Split, Croatia; Monash University, Australia; University of Auckland, New Zealand; Shanghai Jiao Tong University, China; Pontificia Universidad Católica del Perú and Universidad Nacional de Ingeniería, Peru; and Pune University, India.

In 2014, he was the recipient of the Penn State Milton S. Eisenhower Award for Excellence in Teaching. In 2019, he was the recipient of the Society for Experimental Mechanics M.M. Frocht Award for his achievements as an educator in the experimental mechanics field. Trethewey's research focused on the development and analysis of machine dynamics from experimentally acquired data, which included research in experimental techniques instrumentation, signal processing, and system modeling. He supervised over 50 graduate students and has had more than 50 funded research projects from industry and government sources. He published more than 130 technical papers that focused on subjects such as machine dynamics, vibrations, dynamic instrumentation, experimental modal analysis, signal processing, and noise control.

New Faculty Biographies



Sez Atamturktur
ARCHITECTURAL ENGINEERING
CAV group: Structural Vibration and Acoustics

Sez Atamturktur is the Harry and Arlene Schell Professor and head of the Department of Architectural Engineering at Penn State. Previously, she served as associate vice president for research development and provost's distinguished professor at Clemson University. Atamturktur's research, which focuses on uncertainty quantification in scientific computing, has been documented in over 100 peer-reviewed publications in some of the finest engineering science journals and proceedings. Atamturktur's research has received funding from several federal agencies, including the National Science Foundation, the U.S. Department of Energy, the Department of the Interior, the Department of Transportation, the Department of Education, and the Los Alamos National Laboratory, as well as industry organizations and partners, such as the National Masonry Concrete Association and Nucor. She served as the director of the National Science Foundation-funded Tigers ADVANCE project, which focuses on improving the status of women and minority faculty at Clemson. Previously, Atamturktur was the director of the National Science Foundation-funded National Research Traineeship project at Clemson, with funding for over 30 doctoral students and a goal of initiating a new degree program on scientific computing and data analytics for resilient infrastructure systems. In addition, Atamturktur was the director of two separate Department of Education-funded graduate assistantships in Areas of National Need projects that each provided funding for 10 doctoral students. Atamturktur served as one of the four co-directors of Clemson's Center of Excellence in Next Generation Computing and Creativity. Prior to joining Clemson University, Atamturktur served as a technical staff member and researcher in the Applied Physics Division of the Los Alamos National Laboratory.



Nathan Brown
ARCHITECTURAL ENGINEERING
CAV group: Structural Vibration and Acoustics

Nathan Brown joined Penn State as an assistant professor of architectural engineering. He was most recently a member of the digital structures research group at Massachusetts Institute of Technology, where he earned his master's degree in 2016 and his doctoral degree in building technology in 2019. Brown's industry experience includes assisting with building retrofit projects for Elevate Energy, an environmental services organization based in Chicago, and working for BuroHappold Engineering in Boston while a graduate student. His research interests include understanding, improving, and applying advanced computational techniques related to early building design. While he primarily concentrates on structural design and conceptual decisions that relate to structural form and performance, he also considers how this domain interacts with additional design concerns such as energy, daylighting, and acoustics.



Eric Greenwood
AEROSPACE ENGINEERING
CAV group: Rotorcraft Acoustics and Dynamics

Eric Greenwood joined the Penn State Department of Aerospace Engineering as an assistant professor in fall 2019 and also holds an affiliate faculty position with the Graduate Program in Acoustics. He was previously a researcher in the Aeroacoustics Branch of the NASA Langley Research Center, where he led the NASA Mobile Acoustics Facility and was the principal investigator for numerous acoustic flight test programs. He received his doctorate from the University of Maryland in 2011. Greenwood's research is focused on enabling new ultra-low-noise operations of aircraft in and around communities. This includes conducting experiments to understand the physics of aircraft noise generation; developing fast and accurate aircraft noise models; and exploring how real-time aeroacoustic models can be applied to provide aircraft with an intuitive "acoustic awareness" to enable ultra-low-noise operations.



Daning Huang
AEROSPACE ENGINEERING
*CAV group: Structural
Vibration and Acoustics*

Daning Huang joined Penn State as an assistant professor of aerospace engineering in 2019 and established the Aerospace Multi-Physical and Unconventional Systems (APUS) Lab. He received his master's and doctoral degrees in aerospace engineering from the University of Michigan, Ann Arbor in 2014 and 2019, respectively. For his Ph.D. research, Huang developed an extrapolative reduced-order modeling technique and a novel numerical scaling methodology with applications to hypersonic aerothermoelastic problems. Currently, Huang's research centers around the design-oriented reduced-order modeling and uncertainty quantification of multi-disciplinary problems, with particular interests in applications of hypersonic vehicles and vertical lift aircraft.

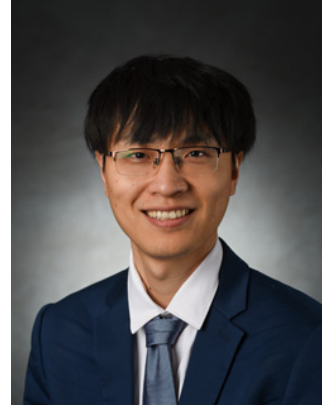

Yun Jing
**GRADUATE PROGRAM
IN ACOUSTICS**
*CAV groups: Acoustic
Materials and Metamaterials
and Biomedical Acoustics*

Yun Jing is currently an associate professor in the Penn State Graduate Program in Acoustics. Before joining Penn State, Jing worked in the Department of Mechanical and Aerospace Engineering at North Carolina State University for over eight years. He received his bachelor's degree in acoustics from Nanjing University, located in Nanjing, China, in 2006. He completed his Ph.D. in architectural acoustics at Rensselaer Polytechnic Institute in 2009, after which he received his postdoctoral training from the Brigham and Women's Hospital, Harvard Medical School, where he conducted research on transcranial ultrasound and nonlinear acoustics. Jing's research interests include metamaterials, noise control, vibration, computational acoustics, therapeutic ultrasound, and ultrasound imaging. He has published over 70 peer-reviewed scientific manuscripts and is a senior member of the Institute of Electrical and Electronics Engineers (IEEE) and a fellow of the Acoustical Society of America. He is the recipient of multiple awards, including the 2018 R. Bruce Lindsay Award, 2018 IEEE Ultrasonics Early Career Investigator Award, and the 2018 MIT Technology Review Innovator Under 35 China Award.



Xin Ning
AEROSPACE ENGINEERING
*CAV group: Adaptive
Structures and Noise Control*

Xin Ning has been an assistant professor in the Penn State Department of Aerospace Engineering since Aug. 2018. His research interests are in the area of lightweight and multifunctional structures. His work has been published in numerous journals—including *Nature*, *Science Advances*, *Nature Biomedical Engineering*, *Advanced Functional Materials*—some of which were selected as cover highlights. Ning was a postdoctoral research associate under the guidance of John A. Rogers from 2015 to 2018 at the University of Illinois at Urbana-Champaign, where he worked on flexible electronics. Ning received his doctorate in aeronautics from California Institute of Technology in 2015 under the guidance of Sergio Pellegrino, where he worked on lightweight thin-walled structures.



Corporate Sponsors



International Liaisons

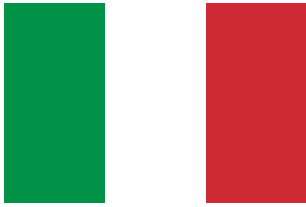

Centro Italiano Ricerche Aerospaziali (CIRA), Italy

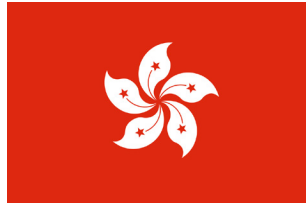

Consortium for Sound and Vibration Research at Hong Kong Polytechnic University, Hong Kong



Deutsches Zentrum für Luft und Raumfahrt (DLR), Germany



Groupe d'Acoustique de L'Université de Sherbrooke, Canada

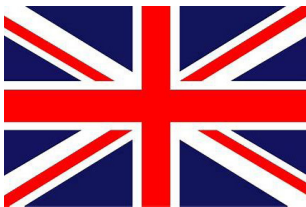

Institute of Sound and Vibration Research (ISVR), United Kingdom



Noise and Vibration Research Group at Katholieke Universiteit in Leuven (KU-Leuven), Belgium



Sound and Vibration Lab at the Korean Advanced Institute for Science and Technology (KAIST), South Korea



Vibration and Acoustics Laboratory at INSA de Lyon, France

Government Liaisons



NASA Langley Research Center



NIST
National Institute of Standards and Technology
U.S. Department of Commerce



U.S.NRC



Vendor Liaisons



CAV Member and Student Honors and Awards

Thomas Blanford, doctoral candidate and assistant research professor in the Applied Research Lab, won second place for Best Student Paper in Underwater Acoustics at the 175th meeting of the Acoustical Society of America in Minneapolis, Minnesota for his paper, "Design Considerations for a Compact Correlation Velocity Log" May 2018.

John Cunsolo, (M.S. 2018) received the INCE-USA Student Paper Award at INTER-NOISE 2018 for his paper titled "Noise Transmission from a Small, Hermetic, Reciprocating Compressor."

Reginald Hamilton, associate professor of engineering science and mechanics, received the 2019 Defense Advanced Research Projects Agency (DARPA) Young Faculty Award.

Stephen Hambric, research professor in acoustics, was invited to give a plenary lecture at the Internoise 2019 Congress in Madrid, Spain. CAV members can view Hambric's lecture, "To Infinity and Beyond, the Amazing Uses of Infinite Structure Theory," given also to the CAV last year, at: cav.psu.edu/seminars.aspx.

Yun Jing, associate professor of acoustics, won the IEEE UFFC Star Ambassador Lectureship Award.

Matthew Neal won first place for Best Student Paper in Architectural Acoustics at the 176th meeting of the Acoustical Society of America for his paper titled "The Room Impulse Response in Time, Frequency, and Space: Mapping Spatial Energy Using Spherical Array Beamforming Techniques" Dec. 2018. He also received the Young Scientist Conference Grant for ICA 2018 in Aachen, Germany, March 2019.

Yoonsang Park, doctoral candidate in electrical engineering, received the following awards:

- Student Poster Award at 2019 International Symposium on Application of Ferroelectrics, Lausanne, Switzerland (July 2019)
 - Poster Award at 2019 International Conference of Advanced Electromaterials, Jeju, Korea (Nov. 2019)
-

Julianna Simon, assistant professor of acoustics and biomedical engineering, won the NSF CAREER Award.

Molly Smallcomb, a doctoral candidate in acoustics, obtained her master's degree in acoustics (Thesis: Focused Ultrasound Histotripsy of Connective Tissue: A tendon model) and received a NSF Graduate Research Fellowship.

Kenji Uchino, professor of electrical engineering, received the following awards:

- IEEE Ultrasonic, Ferroelectrics and Frequency Control Society Distinguished Lecturer (2018 –2019)
 - Mirai-Sendo (Future Leading) Daiwa Securities Chair Professor at Keio University, Japan (2019)
 - Distinguished Honors Faculty, Schreyer Honors College, Penn State (2018 –2020)
 - Senior member of National Academy of Inventors (2019)
 - Wilhelm R. Buessem Award, Center for Dielectrics and Piezoelectrics, Penn State (Sept. 2019); Title: Development of new characterization methods for piezoelectric materials, integration of piezoelectrics into useful devices such as motors, and transformers, and education of students in many generations
-

Gage Walters, a doctoral candidate in mechanical engineering, advised by Andy Wixom and Sheri Martinelli, won the Best Student Paper Award in Structural Acoustics and Vibration at the Acoustical Society of America meeting in San Diego in fall 2019 for his paper titled "Impact of Airfoil Design Uncertainty on the Prediction of Gust Response."

The following students and faculty received the Kenneth T. Simowitz Memorial Award for research publication:

- **Trevor Stout**, co-author Victor Sparrow, "Time-domain Spline Interpolation in a Simulation of N-wave Propagation through Turbulence," JASA 144(3), EL229-EL235, September 2018.
- **Trevor Stout and Victor Sparrow**, "Validation of Numerical Predictions of Sonic Boom Metric Variability due to Turbulence" invited paper, 4aPA2 J. Acoust. Soc. Am., Vol. 143, No. 3, Pt. 2, March 2018. pp. 1912.
- **Anand Swaminathan**, co-authors Steven L Garrett, Matthew E. Poese, and Robert W. Smith, "Dynamic Stabilization of the Rayleigh-Benard Instability by Acceleration Modulation," J. Acoust. Soc. Am. 144(4), October 2018, 2334-2343.

The following individuals received the Kenneth T. Simowitz Memorial Citation:

- **Thomas Blanford**, co-authors Daniel C. Brown and Richard J. Meyer, Jr., "Design Considerations for a Compact Correlation Velocity Log." Proceedings of Meetings on Acoustics, Vol. 33, 070003 (2018)
- **Thomas Blanford, Micah Shepherd, and Trevor W. Jerome**, "A Comparison of Fractional-sized Cellos," Proceedings of Meetings on Acoustics, Vol. 33, 035002 (2018).
- **John Cunsolo**, co-authors Timothy A. Brungart and Stephen Hambric, "Noise Transmission from a Small, Hermetic, Reciprocating Compressor," Proc. of Internoise 2018, 26-29 August 2018, Chicago, IL.
- **Fernando del Solar Dorrego**, co-author Michelle Vigeant, "A Study of the Just Noticeable Difference of Early Decay Time (EDT)," In Auditorium Acoustics 2018 (Vol. 40, pp. 273-282). Institute of Acoustics.
- **Zhendong Huang**, co-author Victor Sparrow, "An Improved Mach Cut-off Model based on a 3-D Ray Tracing Method and Realistic Atmospheric Data," Invited paper at the Acoustical Society of America, Minneapolis, May 2018.
- **Connor McClusky**, co-authors Stephen C. Conlon and Manton J. Guers, "Extreme Value Statistics of Flow Induced Noise and Vibration." Proceedings of InterNOISE 2018.
- **Cameron McCormick**, co-author Micah Shepherd, "Optimal Design and Position of an Embedded One-dimensional Acoustic Black Hole," Proceedings of InterNOISE 2018.
- **Peter Moriarty**, co-authors Michelle Vigeant, Pan Liu, Rick Gilmore, and Pamela Cole, "Comparing Theory, Consensus, and Perception to the Acoustics of Emotional Speech," invited paper at the Acoustical Society of America, Vancouver, November 2018.
- **Matthew Neal**, co-author Michelle Vigeant, "Achieving Realism and Repeatability of an Orchestra Simulated within a Concert Hall," invited paper at the Acoustical Society of America, Minneapolis, May 2018.
- **Matthew Neal and Michelle Vigeant**, "The Room Impulse Response in Time, Frequency, and Space: Mapping Spatial Energy using Spherical Array Beamforming Techniques," invited paper at the Acoustical Society of America, Vancouver, November 2018.
- **Matthew Neal and Michelle Vigeant**, "A Measurement Database of U.S. and European Concert Halls for Realistic Auralization and Study of Individual Preference," Proceedings of Auditorium Acoustics 2018, Institute of Acoustics.
- **Nicholas Ortega**, co-authors Michelle Vigeant and Victor Sparrow, "Perceptual Characterization of Mach Cut-off Sonic Booms," invited paper at the Acoustical Society of America, Minneapolis, May 2018.
- **Harshal Patankar** co-author Victor Sparrow, "Quantifying the Effect of Uncertainty in Meteorological Conditions on Aircraft Noise Propagation," Proc. of Internoise 2018, 26-29 August 2018, Chicago, IL.
- **Andrew Pyzdek**, and David C. Swanson, "Sparse Array Performance in Channels of Limited Coherence," invited paper at the Acoustical Society of America, Minneapolis, May 2018.
- **Andrew Pyzdek and David C. Swanson**, "Effects of Lag Redundancy on Array Beam Patterns and Redundancy Patterns for Extended Co-prime Arrays," invited paper at the Acoustical Society of America, Minneapolis, May 2018.
- **Stephen Wells**, co-authors Stephen Hambric and Timothy Brungart, "Experimental Investigation of Water-cooled Centrifugal Chiller Sound Radiation," Proceedings of Noise and Vibration Emerging Methods, May 2018.
- **Janet Xu**, co-author Victor Sparrow, "Investigation of Deturbing Methods for Sonic Boom Signatures," invited paper at the Acoustical Society of America, Minneapolis, May 2018.

CAV 2019 Graduate Student Theses

| NAME | PROGRAM | DEGREE | TITLE |
|---------------------|-----------------------------------|--------|--|
| Hromisin, Scott | Aerospace Engineering | Ph.D. | Aeroacoustic Characterization of Dual-Stream, Supersonic, Rectangular Exhaust Jets |
| Hakoda, Christopher | Engineering Science and Mechanics | Ph.D. | Extending the Applicability of the Partial Wave Method for Interpreting Waves in Elastodynamic Waveguides |
| Prasad, Chitrarth | Aerospace Engineering | Ph.D. | Simulation of Supersonic Jet Noise Reduction using Fluid Inserts for Low Bypass Ratio Turbofans |
| Choi Minkyu | Materials Science and Engineering | Ph.D. | Polarization Orientation Dependence of Piezoelectric Loss and Proposed Crystallographic Characterization Methodology |
| Zechmann, Edward | Acoustics | Ph.D. | Characterization of Noise with Fractional-octave-band Filters and the Variance and Kurtosis of the Sound Pressure |
| Hasanian, Mostafa | Engineering Science and Mechanics | Ph.D. | Mutual Nonlinear Interaction of Ultrasonic Guided Waves in Plate, Applications for NDE |
| Ren, Liqiang | Engineering Science and Mechanics | Ph.D. | Passive and Active Manipulation of Micro-particles with Acoustic Waves |
| Saetti, Umberto | Aerospace Engineering | Ph.D. | Rotorcraft Flight Control Design with Alleviation of Unsteady Rotor Loads |
| Jin, Jiang | Civil Engineering | Ph.D. | The Correspondence Between Microstructural Features and Acoustic Nonlinearity |
| Smith, Cory | Acoustics | Ph.D. | Measurement of Turbulent Boundary Layer Unsteady Wall Pressures Beneath Elastomer Layers of Various Thicknesses on a Plate |
| Kim, Jeong | Engineering Science and Mechanics | Ph.D. | Closed-loop Finite Element Design of Array Ultrasonic Transducers for High Frequency Applications |
| Neal, Matthew | Acoustics | Ph.D. | A Spherical Microphone and Compact Loudspeaker Array Measurement Database for the Study of Concert Hall Preference |
| Tipton, Nathan | Acoustics | M.S. | An Outdoor Sound Propagation Model in Concert with Geographic Information System Software |
| Trowbridge, Michael | Mechanical Engineering | M.S. | Fluidic Flexible Matrix Composite Damped Vibration Absorbers for Stiff-Inplane Hingeless Rotor Blades |
| Nagrале, Shashank | Engineering Science and Mechanics | M.S. | Damping Enhancement in Hybrid Composite by Embedding Nickel-titanium Wires Subjected to Microstructure Treatments |
| Witham, Timothy | Geosciences | M.S. | Ultrasonic Monitoring of Laboratory Scale Hydraulic Fracturing |
| Gawelko, Lexi | Civil Engineering | M.S. | Can Meta-Soil Attenuate Seismic Waves? |
| Kim, Jeffrey | Engineering Science and Mechanics | M.S. | Fabrication and Characterization of High Damping Carbon Fiber Composites with Carbon Nanotube Interlayers |

Penn State Graduate Program in Acoustics Distance Education Courses

The Graduate Program in Acoustics at Penn State is a unique interdisciplinary program leading to master's and doctoral degrees in acoustics. The program is focused entirely on acoustics, a subject touching many diverse disciplines such as architectural acoustics, biomedical ultrasound, noise and vibration control, transducer design, underwater acoustics, signal processing, aeroacoustics, structural vibration, speech and communication, outdoor propagation, computational methods, and much more.

www.acs.psu.edu

Fall 2020 Distance Education Course Schedule

CLASS DATES

Aug. 24, 2020–Dec. 18, 2020

- All classes video streamed and archived for review
- All courses available for credit or audit

COURSE SCHEDULE

ACS 501: ELEMENTS OF ACOUSTICS AND VIBRATION

Instructor: Dan Russell

Credits: 3

Prerequisite: Undergraduate physics, differential equations, and complex numbers

Course Material: This course introduces the fundamentals of acoustics and vibration, focusing on structural vibration and sound waves in simple objects such as mass-spring systems, strings, rods, and plates. The fundamental concepts of vibration are presented along with applications to engineering and industrial problems. Topics covered: simple harmonic oscillator; mechanical resonance and damping; forced vibration and normal modes; transverse waves on strings; boundary conditions and standing waves; elasticity; longitudinal, torsional, and transverse vibration of bars; transverse vibrations of membranes; and flexural vibrations of thin plates

Text: TBA

ACS 502: ELEMENTS OF WAVES IN FLUIDS

Instructor: Julianna Simon

Credits: 3

Prerequisite: Undergraduate physics and differential equations

Course Material: This course lays the fundamental groundwork for the propagation of acoustic waves in fluids. Topics include: basic equations of fluid dynamics; development of the linear wave equation; acoustic lumped elements; speed of sound; linear acoustic wave propagation of plane and spherical waves; radiation of sound from sources and arrays; sound intensity and power; reflection and transmission of sound at boundaries; absorption of sound; propagation of sound in pipes and acoustic filters

Text: Fundamentals of Physical Acoustics, Blackstock, David T., 2000 (Wiley)

ACS 597: SIGNAL ANALYSIS FOR ACOUSTICS AND VIBRATION

Instructor: Tom Gabrielson

Credits: 3

Prerequisite: Undergraduate physics, differential equations, and complex numbers, as well as some familiarity with programming in MatLab or equivalent

NOTE: This course replaces ACS 516: Acoustical Data Measurement and Analysis. Students may enroll in this course if they have not taken ACS 516. Students who have previously taken ACS 516 may not enroll in this course.

Course Material: Time- and frequency-domain analyses for sampled, discrete-time acoustic and vibration measurements. Development, application, and consequences of filtering, spectral analysis, and correlation for single- and multi-channel data

Text: Instructor notes

Software: MatLab or MatLab Student Version, available at webapps.psu.edu

ACS 597: COMPUTATIONAL ACOUSTICS

Instructor: Victor Sparrow

Credits: 3

Prerequisite: Co-Requisite Registration: ACS 501: Elements of Acoustics and Vibration, and ACS 502: Elements of Waves in Fluids

Course Material: The purpose of this course is to provide a good background in computational acoustics by providing instruction in using modern commercial packages for solving acoustics problems as well as a good understanding of the fundamental background knowledge so that the commercial packages can be used correctly and effectively. Students will be exposed to many important tools in acoustics, including symbolic manipulation programs such as Mathematica; finite differences, finite elements, and boundary elements; scientific visualization; and sound propagation algorithms. Topics covered include: using PCs and UNIX workstations; visualizing and postprocessing acoustic data; transient analysis of acoustics waves; modal and forced responses of arbitrary cavities using finite elements; acoustic radiation and scattering predicted using boundary elements and/or infinite elements; and first pass at parallel processing.

Text: Instructor notes

Software: MatLab or MatLab Student Version, available at webapps.psu.edu. Mathematica or Mathematica for Students, available at webapps.psu.edu.

ACS 597: AUDIO SIGNAL PROCESSING

Instructors: Dave Swanson

Credits: 3

Prerequisite: ACS 513 or ACS 597: Signal Analysis for Acoustics and Vibration or ACS 516 or ACS 597: Advanced Signal Analysis for Acoustics and Vibration

Course Material: Essential signal processing and acoustical modeling associated with audio systems used in broadcasting, communications, music recording, and video foley production. Topics covered: details of digital waveform compression processes and formats; digital signal processing for audio filters, modulation, filters, compressors, harmonizers, and reverberation special effects; digital audio workstations; the history and types of microphones and guitar pickups; digital, transistor, and vacuum tube amplifiers; and loudspeaker systems

Text: Instructor notes

Spring 2021 Distance Education Course Schedule

CLASS DATES

Jan. 11, 2021–May 7, 2021

TENTATIVE COURSE SCHEDULE

(Suggestions can be sent to acousticsde@psu.edu)

ACS 514: ELECTROACOUSTIC TRANSDUCERS

Credits: 3

Prerequisite: Undergraduate physics, basic linear circuit theory, differential equations, and complex numbers. Must have working knowledge of required software.

ACS 515: ACOUSTICS IN FLUID WAVES

Credits: 3

Prerequisite: ACS 502: Elements of Waves in Fluids or ACS 597B: Introduction to Acoustics and Fluid Media, ACS 598E: Engineering Mathematics I or equivalent, or instructor consent

ACS 597: ADVANCED SIGNAL ANALYSIS FOR ACOUSTICS AND VIBRATION

Prerequisite: ACS 597: Signal Analysis for Acoustics and Vibrations

NOTE: This course replaces ACS 513: Digital Signal Processing. Students may enroll in this course if they have not taken ACS 513. Students who have previously taken ACS 513 may not enroll in this course.

ACS 598: ENGINEERING MATHEMATICS I

Credits: 3

Prerequisite: Undergraduate physics, differential equations, and complex numbers



Technical Research Group Highlights

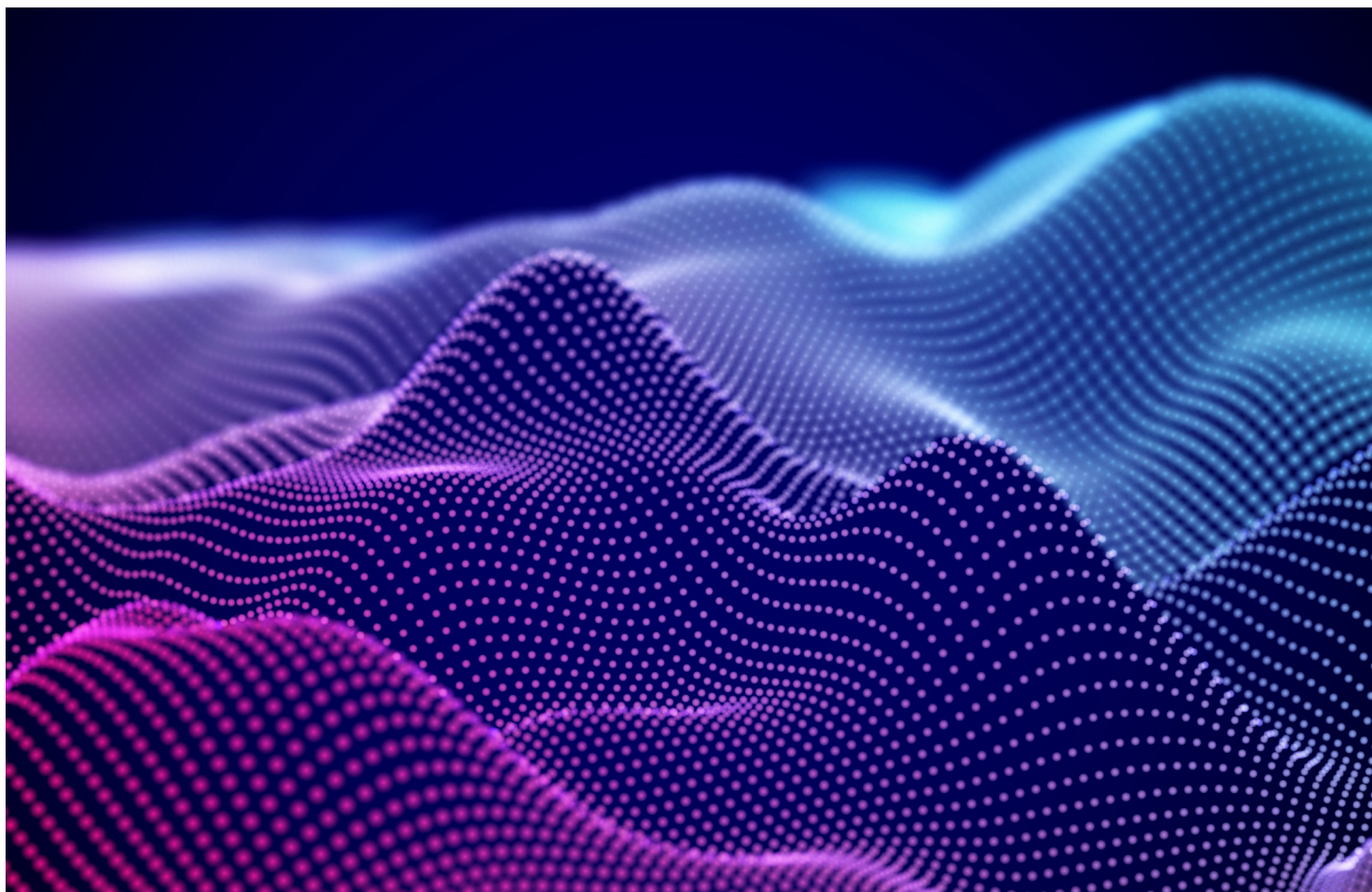

- 21** Acoustic Materials and Metamaterials
- 27** Adaptive Structures and Noise Control
- 34** Biomedical Acoustics
- 37** Flow-Induced Noise
- 41** Propagation and Radiation
- 48** Rotorcraft Acoustics and Dynamics
- 53** Structural Vibration and Acoustics
- 61** Systems and Structures Health Management

Acoustic Materials and Metamaterials

Group Summary

The Acoustic Materials and Metamaterials technical group performs research in many areas involving the interaction between acoustics and materials. Example topics include material characterization, manufacturing techniques for novel materials, novel applications such as acoustic cloaking, metamaterial inverse design, active metamaterials, and structural vibration control through novel materials.

The Acoustic Materials and Metamaterials technical group is happy to welcome Yun Jing to Penn State. Jing's work encompasses many technical groups within the CAV including this group.

Other group work involves designing a metamaterial by performing unit cell analysis with subwavelength geometry. There are several techniques used for unit cell analysis when designing acoustic properties of interest for metamaterial



Group Leader: Amanda Hanford
Assistant research professor in acoustics

applications. Such techniques include, but are not limited to, band diagrams, effective material properties, or half-space homogenization. Different work from the group evaluates the challenges and tradeoffs between analysis techniques and types of structures that lend to one method or another. Unit cell analysis methods are typically used to perform trade space exploration, including validation and parametric studies for metamaterial design.

Below are some highlights of this group's recent work:

Undersea advanced technology-active/adaptive acoustic metamaterial for vibration control

PIs: Ben Beck, assistant research professor in the Applied Research Lab

Student: Aaron Stearns, doctoral candidate in mechanical engineering

Sponsor: NAVSEA 073

Summary: Acoustic metamaterials are composite materials exhibiting effective properties and acoustic behavior not found in traditional materials. Primarily through periodic subwavelength resonant inclusions, acoustic metamaterials can enable steering, cloaking, lensing, and band gap control of acoustic waves. The goal of this research is theoretical and experimental design, analysis, and optimization of actively controlled and adaptable acoustic metamaterials for control of structural vibrations.

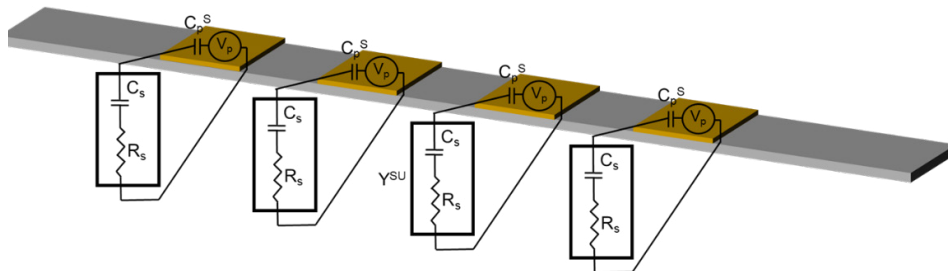

Acoustic metamaterials survey study

PIs: Amanda Hanford, assistant research professor in acoustics

Sponsor: 3M

Summary: The objective of this work is to develop design and modeling expertise to optimize decorated membrane (DM) acoustic metamaterials for noise control solutions.

A meta-surface to control surface wave propagation

PIs: Parisa Shokouhi, associate professor of engineering science and mechanics; Cliff Lissenden, professor of engineering science and mechanics; and Mary Frecker, professor of mechanical engineering

Student: Daniel Guzman, doctoral candidate in mechanical engineering

Sponsor: National Science Foundation (NSF)

Summary: This project will generate new fundamental knowledge on the control of surface wave motion. Surface waves are generated by natural or man-made sources such as earthquakes, explosions, traffic, or construction operations. Many electronics include devices that also use the principles of surface wave propagation. The ability to control surface wave motion has broad implications across length scales: from design of miniature electronic devices to earthquake or vibration isolation of critical structures. This award supports fundamental research needed to purposefully control the propagation of surface waves to reflect or divert wave energy. The control mechanism is inspired by meta-surfaces, surfaces structured to manipulate surface wave propagation. A typical structure consists of elements installed on or inserted into the surface. Finding the right elements remains a challenge, for which no rational design process is currently available. The state-of-the-art approach is parametric; a range of materials and shapes are attempted until the desired control is achieved. The proposed approach is fundamentally different in that it relies instead on modifying the surface condition. The elements will be designed such that the necessary conditions on the surface are satisfied, leading to a systematic and optimized strategy for creating a meta-surface. Since the imposed surface conditions are scale-independent, the knowledge gained in this research has potential implications across length scales. Examples include the design of next-generation filters and sensors, vibration barriers, as well as seismic and explosive shields for vulnerable structures or even towns. Besides contributing to the progress of science, this research will contribute to advancing societal welfare and securing the national defense. This project will provide multidisciplinary training and career preparation for two engineering doctoral students. Additionally, the PIs will incorporate the methods and findings of the research into graduate and undergraduate courses, as well as secondary level teaching at K-12 schools in Pennsylvania and across the country through a collaboration with Penn State's Center for Science and the Schools (CSATS).

The proposed research presents a new approach for controlling surface wave motion based on a fundamental study of the boundary conditions' influence on the surface wave propagation. This enables implementation of a rational design philosophy for meta-surfaces to control Rayleigh surface waves. The proposed boundary-condition (BC) based strategy will be implemented in order to create a resonant meta-surface to minimize the transmitted energy in a prescribed frequency bandwidth to a particular location. An optimization procedure will be developed to find the optimal resonator topology, such that the desired BCs are satisfied and to determine the resonator spacing. A method to broaden the frequency stopband will be tested. This approach is fundamentally different from the commonly used frequency tuning and parametric design process. Since the BCs are frequency-independent, the new approach is transportable across length scales.

Clamped resonant meta-plate

PI: Parisa Shokouhi, associate professor of engineering science and mechanics, and Cliff Lissenden, professor of engineering science and mechanics

Student: Christopher Hakoda, graduate student

Sponsor: Penn State College of Engineering Multidisciplinary Research Seed Grants

Publication: C. Hakoda, C. Lissenden, P. Shokouhi, "Clamping Resonators for Low-Frequency S0 Lamb Wave Reflection," *Applied Sciences*, 9(2), 257.

Summary: A recent elastic metamaterial study found that resonators that "clamp" a plate waveguide can be used to create a frequency stop-band gap. The result was that the resonator array can prohibit the propagation of an A0 Lamb wave mode. This study investigates whether the concept can be extended to S0 Lamb wave modes by designing resonators that can prohibit the propagation of S0 Lamb wave modes in a 1-mm aluminum plate waveguide at 50 kHz. The frequency-matched resonators did not reduce the transmitted signal, leading to the conclusion that the design concept of frequency-matched resonators is not always effective. On the other hand, the resonators designed to clamp the upper surface of the plate were very effective and reduced the transmitted signal by approximately 75%.

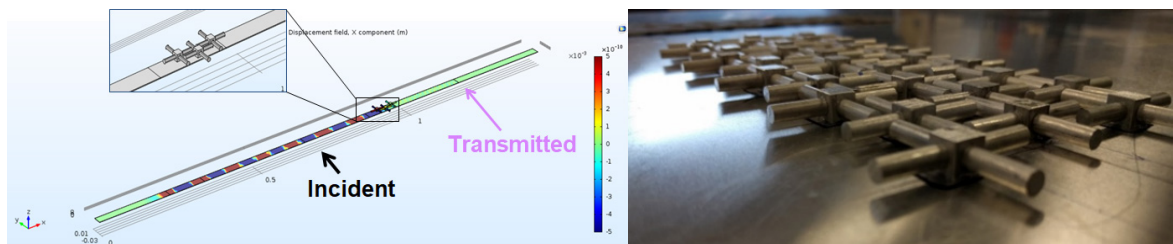

Resonant metamaterials

PIs: Parisa Shokouhi, associate professor of engineering science and mechanics, and Cliff Lissenden, professor of engineering science and mechanics

Student: Lexi Gawelko, 2019 graduate in civil engineering (B.S.)

Summary: This research designed resonators which can block bulk waves at seismic range (Hz) of frequencies. The size of the resonators is orders of magnitude smaller than the seismic wavelength.

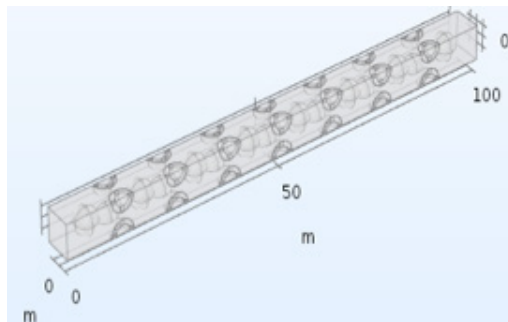

Architected micro-lattices for wide-band vibration attenuation

PI: Yun Jing, associate professor in acoustics

Student: Nikhil JRK Gerard, Department of Mechanical and Aerospace Engineering, North Carolina State University

Summary: Elastic metamaterials are artificial periodic structures that exhibit frequency ranges known as bandgaps, where wave propagation is prohibited. Conventional elastic metamaterials are limited in their bandwidth, since they require impractical mass and size, with respect to the operating wavelength. Additionally, their designs also greatly restrict them from catering more than one functionality. This project introduces a micro-lattice-based metamaterial that can attenuate elastic waves in all directions and over a wide frequency range, alongside possessing the second order functionality of exhibiting a negative Poisson's ratio. Such a thin lightweight material with dual functionality could thus pave the way for a variety of unconventional wave-based devices, alongside bolstering the interest for futuristic multi-functional materials.

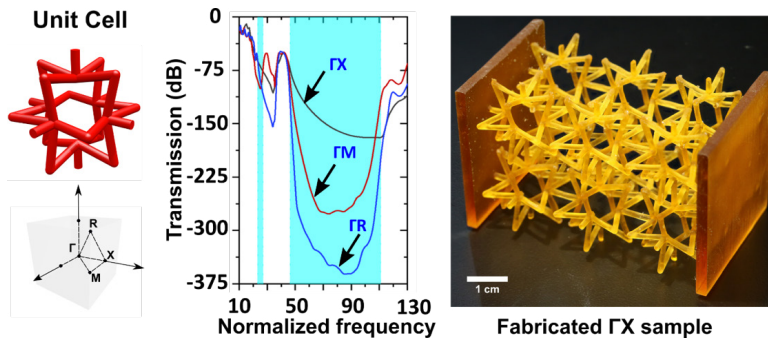

Exceptional points for sound control with non-Hermitian acoustic metasurfaces

PI: Yun Jing, associate professor in acoustics

Student: Nikhil JRK Gerard, Department of Mechanical and Aerospace Engineering, North Carolina State University

Sponsor: NSF

Summary: This project focuses on creating a new class of non-Hermitian diffractive acoustic metasurfaces. Acoustic metasurfaces are thin artificial materials that can control sound waves. These two-dimensional materials are empowered with extraordinary control over the reflected and transmitted sound, which enables the unprecedented shaping of acoustic wavefronts. This research establishes analogies between non-Hermitian quantum mechanics and acoustics that would result in a paradigm shift in the design of acoustic metasurfaces. The project will broadly advance the field of acoustic metasurfaces through discovering new mechanisms for designing materials with novel functionalities. This will have applications in noise control, architectural acoustics, and communication. The outcome of this research will also encourage future fundamental research where acoustics could serve as a platform to materialize quantum mechanics concepts.

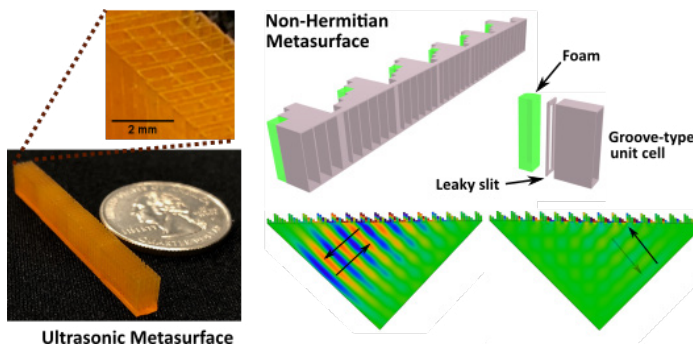

A bottom-up approach to modeling wave propagation and scattering in polycrystalline materials

PI: Christopher Kube, assistant professor of engineering science and mechanics

Student: Anubhav Roy, doctoral candidate in engineering science and mechanics

Publication: C. Kube, A. Arguelles, "Pressure influence on elastic wave attenuation in polycrystalline materials," J. Acoust. Soc. Am. 146, 4183 (2019)

Summary: This research focuses on ultrasonic attenuation in generally textured polycrystalline materials. The work has been focused on some theoretical work related to surface acoustic waves on a piezoelectric substrate in the presence of an external electric field. Anubhav Roy received a Best Poster Award at the 2019 International Congress on Ultrasonics held in Bruges, Belgium.



Advancing the science of metallic 3D printing through ultrasonic characterization of laser generated melt pools

PIs: Christopher Kube, assistant professor in engineering science and mechanics

Summary: Over the past decade, we have witnessed the emergence of functional additively manufactured (AM) metallic parts integrated into modern technology. This is evidenced in the usage of AM metallic rockets, submarine propellers, nuclear reactor components, munitions, and car components. While advances in this area are being realized, these advances are not addressing the full potential of metal AM. A significant advance will be seen when the AM process produces parts that perform exactly as expected in their intended application, without exception. An increase in fundamental knowledge involving the influence of the AM process on the resultant metallic microstructure, along with quality control procedures that have microstructure-property sensitivity, are two areas of need that can help fulfill the promise of metallic AM.

Many applications involving metallic AM parts are being undertaken by the Penn State Ultrasonics Laboratory (PennSUL) to address the two areas of need. Specifically, research in the development of ultrasonic technology to monitor in situ laser generated melt pools is provided. Ultrasound is a unique modality that allows us to characterize mechanical properties and microstructure as they manifest as the melt pool solidifies. Such characterization has potential to (1) enhance our knowledge of the AM process in relation to microstructure formation and (2) provide information on the quality of the formed microstructure and the resultant part.

Acoustic signals associated with laser-substrate interaction in powder bed fusion additive manufacturing process

PIs: Robert Smith, associate research professor in the Applied Research Lab, and Ted Reutzel, associate research professor in the Applied Research Lab

Summary: During the powder bed fusion additive manufacturing process, flaws are sometimes produced in the component. It is desirable to detect these flaws during the deposition process, so that they might be remediated before they become captured within the part. A pilot study was conducted to see if acoustic data might show some signature or variation when such flaws are produced. Acoustic data was collected within the chamber during the powder bed fusion additive manufacturing process in a 3D Systems Launches Pro-X 320 Direct Metal Printer. A PCB fourth-inch model 378A14 pre-polarized piezo-electric pressure microphone with integrated preamplifier was the sensor used to detect acoustic signals. Tonal noise associated with pumps obscured the spectral region below 10 kHz, but significant acoustic output associated with the laser-substrate interaction was present from 20-70 kHz. A small cylinder was produced for test, during which intentional process variations were introduced.

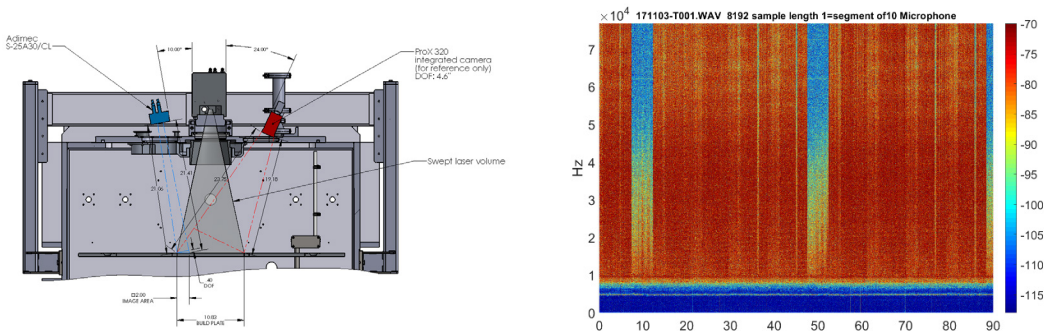

Figure: (Left) setup of AM build chamber. (Right) High pass filtered spectrogram of microphone data showing acoustic energy in 20-70 kHz range.

Adaptive Structures and Noise Control

Group Summary

The mission of the Adaptive Structures and Noise Control Technical Group is to pursue strategies for reducing vibration and noise in engineering systems. This involves the development of active materials and devices, accurate modeling approaches, passive control methods, discrete and distributed sensors and actuators—as well as placement strategies, structural integration methods, fast and stable adaptive control algorithms, and experiments to evaluate real-world performance. In complex mechanical/acoustical systems with multiple sensing and source/actuator locations, significant challenges remain.



Group Leader: Jose Palacios
Associate professor
of aerospace engineering

Below are some highlights of this group's recent work:

Jose Palacios, associate professor of aerospace engineering, and his students are pursuing several projects in vibration control, acoustic measurements, and adaptive structures fields. Palacios' group is also active in the field of aircraft icing and rotor aeromechanics and is currently working on the following: The effects of tip leakage on jet engine partially melted ice crystal ice accretion (NASA fellowship); ice adhesion strength modeling and verification of controlled surface roughness erosion resistant coatings (Vertical Lift Research Center of Excellence task); engine icing ice accretion modeling; acoustic quantification of co-axial eVTOL rotor and effects of rotor place position; anechoic wind tunnel testing of anti-phase vortex reduction control for rotor noise suppression (NASA Ames); rain erosion testing of ice protective coatings; rotor blade structural design and wind tunnel aerodynamic testing of the Titan Dragonfly (NASA-APL); design and construction of a tilt-rotor aerodynamic download testing facility (Bell Textron).

In the past year, this group has tested co-axial half-scale Dragonfly rotors at the NASA 14-by-22-foot wind tunnel, novel low-power ice protection systems at the NASA Glenn Icing Wind Tunnel on full-scale Reaper UAV wings, and preparing for construction of a 10-foot in diameter tilt-rotor download facility at the Penn State University Park Airport.

Endoscopic flexible pancreatic tumor ablation system with reduced force effector and specialized ablation zone

PIs: Mary Frecker, professor of mechanical engineering, and Snook (AMI)

Student: Brad Hanks, doctoral candidate in mechanical engineering, and Fariha Azhar, undergraduate student in mechanical engineering

Sponsor: National Institutes of Health, with Actuated Medical Inc.

Summary: We are developing specially shaped deployable probe tips for radio frequency ablation of pancreatic cancer.

Modeling and experimental verification of a low-power pneumatic ice protections system for fixed-wing UAS

PI: Jose Palacios, associate professor of aerospace engineering

Student: Carter Forry, master's degree in aerospace engineering, May 2019

Sponsor: Airforce, Invercon LLC.

Summary: A novel low power, low weight, erosion resistant, pneumatic actuators combined with a bi-stable latch is modeled and experimentally evaluated. The system has been demonstrated in a full-scale helicopter rotor blade using centrifugal pumping to inflate and deflate the rotor leading edge. The configuration uses a metallic leading-edge cap rather than neoprene as it is used by other pneumatic systems. The small deformation on the metallic cap create sufficient transverse shear stresses to debond accreted ice. For fixed-wing UAVs, due to the lack of centrifugal forces to remove the ice and aerodynamic forces pushing the ice onto the wing preventing ice removal, bi-stable latches are introduced. The bi-stable latches release during the inflation process, providing a transient non-symmetric input to the leading-edge cap and assisting with the removal of the debonded ice. The configuration was successfully tested in a full-chord Predator wing at the NASA Glenn Icing Research Tunnel in the fall of 2019.

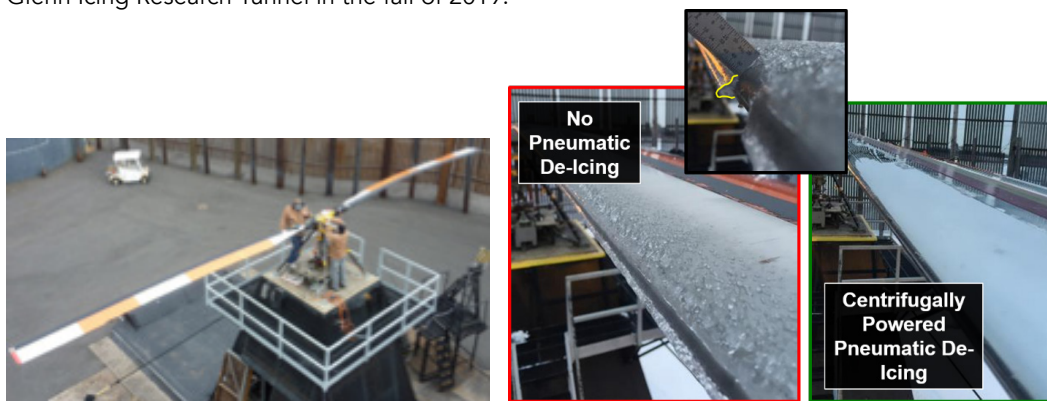

Full-scale rotor blade used for testing of the centrifugally powered pneumatic de-icing configuration and sample results of ice protection using semi-passive centrifugally powered pneumatic de-icing.

Anechoic wind tunnel testing of anti-phase vortex reduction control for rotor noise suppression and co-axial rotors

PI: Jose Palacios, associate professor of aerospace engineering

Students: Sihong Yan, doctoral candidate in aerospace engineering, and Raja Akif Bin Raja Zahirudin, doctoral candidate in aerospace engineering

Sponsor: NASA Ames

Summary: Palacios' group has become active in the field of unmanned aerial system (UAS) acoustic testing, as the market of unmanned aircraft systems has been developing in recent years. The 2018 aerospace forecast report from Federal Aviation Administration estimates that 1.2 million model or hobbyist UAS units and 110,604 non-model or commercial UAS units are registered in United States. The forecast also predicts that total amount of hobbyist UAS units will increase to 2.4 million and 451,800 commercial units will be operated by 2022*. Multi-rotor UAS, due to its maneuverability, is a UAS configuration that has received increasing attention. Commercial manufacturers are developing heavy lift multi-rotor UAS for cargo and transportation purposes, such as the Boeing Heavy Lift Project+ or the Uber Elevate Project. Certification procedures will be needed to ensure the safety of these commercial UAS units in the future.

Amazon, UPS, Domino's Pizza, Uber, and other companies planning drone delivery could cause noise pollution that is more annoying than that of ground vehicles even at the same noise level+. One of the key reasons is related to how slowly most commercially available UAS move, providing "loitering" noise. The integration of UAS to commercial applications is inevitable, but the acceptance of such applications will require understanding and mitigation of UAS acoustics perceived as irritating to the population.

Strategically, developing a rotor able to mitigate the noise of the vehicle is critical for public acceptance. Low acoustic rotors are also of great interest to our armed forces. The capability to conduct high quality acoustic testing of UAS configurations at Penn State is being leveraged to demonstrate a novel anti-phase vortex rotor technology developed by NASA.

The team has the capability to fabricate custom blades, measure 6-axis loads, acoustics, and customize rotor placement configurations for rotors of up to a 24-inch diameter. An open section anechoic wind tunnel facility houses a 19-microphone array that surrounds the rotor system.

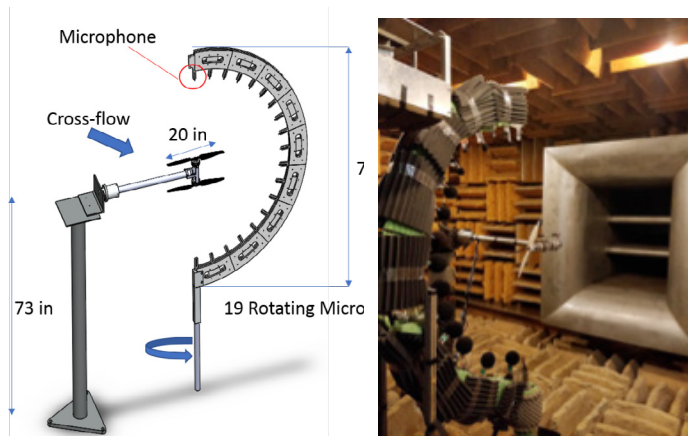

Schematic of co-axial UAS system with concentric microphone array and photograph of the system installed in the anechoic wind tunnel.

The capabilities of the configuration are valuable for the comparison of the baseline rotor and the novel anti-phase vortex rotor and for the fundamental understanding of UAS rotor and motor noise. An example result is shown below.

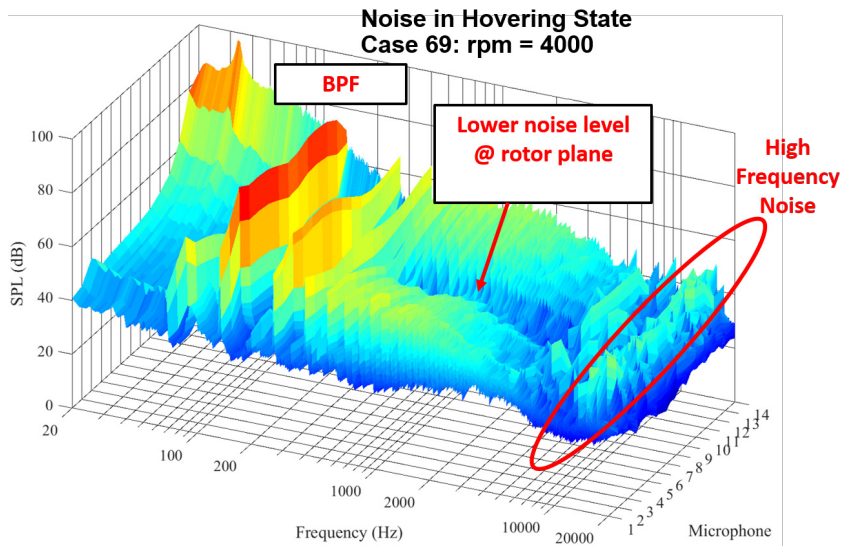

Sound pressure collected by the microphone array for a hover condition. The facility can provide forward speeds of up to 10 m/sec.

Federal Aviation Administration, "FAA Aerospace Forecast Fiscal Years 2018–2038." TC18-0004, 2018.

* Christian, A., and Cabell, R., "Initial Investigation into the Psychoacoustic Properties of Small Unmanned Aerial System Noise," 17th AIAA Aviation Technology, Integration, and Operations Conference (AVIATION 2017); 5-9 Jun. 2017; Denver, CO; United States.

Design of multifield responsive material systems

PIs: Mary Frecker, professor of mechanical engineering, and Zoubeida Ounaies, professor of mechanical engineering

Student: Wei Zhang, doctoral candidate in mechanical engineering

Summary: We are developing finite element modeling and systematic design optimization methods for active materials that respond to multiple applied fields such as electric and magnetic.

Design for additive manufacturing (DFAM) of cellular contact aided compliant mechanisms (C3M) for energy absorption

PIs: Mary Frecker, professor of mechanical engineering

Students: Jivtesh Khurana, doctoral candidate in mechanical engineering, and Brad Hanks, doctoral candidate in mechanical engineering

Summary: Energy-absorbing C3M are expected to be useful for applications such as vehicle armor. We are developing a DFAM approach including finite element modeling of structural during impact and thermal response during fabrication.

Loss mechanisms in piezoelectric single crystals and ceramics

PI: Kenji Uchino, professor of electrical engineering

Students: Hossein Daneshpajoo, doctoral candidate in electrical engineering, and Yoonsang Park, doctoral candidate in electrical engineering

Sponsor: Office of Naval Research

Summary: We clarify the macro- and micro-scopic mechanisms of the losses in piezoelectric single crystals and ceramics, aiming at development of high-power density piezoelectric materials and devices for the Navy's application.

Two research topics were conducted during the fiscal year of 2019:

(1) DC bias electric field and stress dependence of piezoelectric losses: Characterization of dielectric, elastic, and piezoelectric losses in PZT piezo-ceramics has been conducted by using our original Burst Mode HiPoCS™. We clarified the origin of the superiority of the Bolt-clamped Langevin transducers.

(2) Partial-electrode configuration characterization of piezo-ceramic specimens: We succeeded to measure both E- and D-constant condition loss performances with our original partial-electrode configurations under a mechanical excitation of the piezo-ceramic specimens.

| Excitation | Mode | k_{33} Side Load |
|-----------------------|--------------------------------|--------------------|
| Electrical Excitation | IEEE Standard | |
| Mechanical Excitation | Extensive Mode (Open circuit) | |
| | Extensive Mode (Short circuit) | |
| | Intensive Mode | |

Partial-Electrode configurations for measuring both intensive and extensive losses in PZT piezo-ceramics.

Piezoelectric actuators for synthetic jets

Student: Tianliang Yu, doctoral candidate in aerospace engineering

Sponsor: Boeing

Summary: Synthetic jet devices are attractive for active flow control because they do not require a pressurized air source. Instead, they cyclically ingest and expel air with zero net mass flow. High-performance ferroelectric materials can effectively drive synthetic jets; however, which materials and what associated optimal actuator geometries yield the best performance are unknown. A low-order coupled electro-elasto-acoustic model was developed as the basis for performance analysis and initial device optimization. A linear model does not accurately capture device response at different drive levels. A first-principles nonlinear damping model was developed to more accurately model losses. The optimal device determined using the nonlinear model offers about twice the net jet momentum as the device obtained using the linear model.

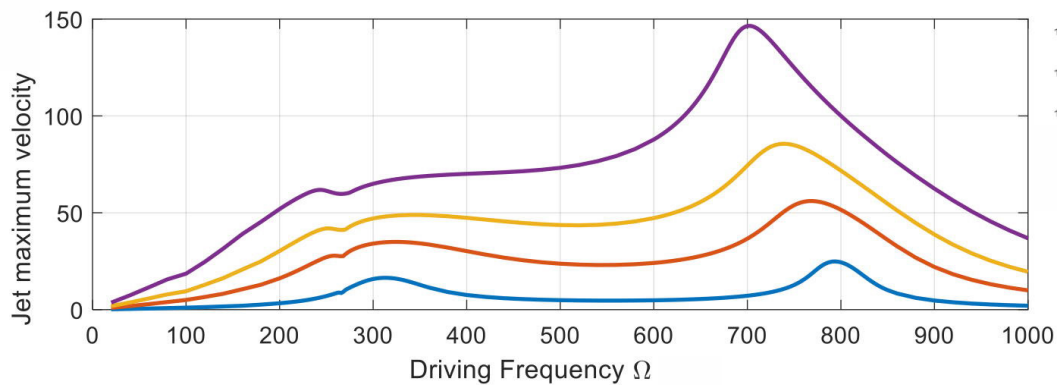

Articulated tensegrity structures for space applications

Student: Kaila Roffman, doctoral candidate in aerospace engineering

Sponsor: U.S. Government

Summary: Spacecraft having extended configurations must be stowed for launch compactly, with final stiffness adequate to maintain shape and stability under dynamic disturbances. Tensegrity structures are of interest for their potential to provide novel deployable structures (booms, arrays) for space applications, as well as articulated structures that can be reconfigured and adjusted during mission operation. Research issues include tendon actuation; metrology, precision and control; and reachable states.

Multifunctional lithium ion batteries with silicon anodes

PIs: Chris Rahn, J. Lee Everett Professor and associate dean for innovation, Mary Frecker, professor of mechanical engineering, and Donghai Wang, professor of mechanical engineering

Students: Jun Ma, Cody Gonzalez, doctoral candidate in mechanical engineering

Sponsor: National Science Foundation

Summary: Multifunctional Li-ion batteries that are capable of actuation and sensing, as well as energy storage, and being developed using modeling and experimental approaches.

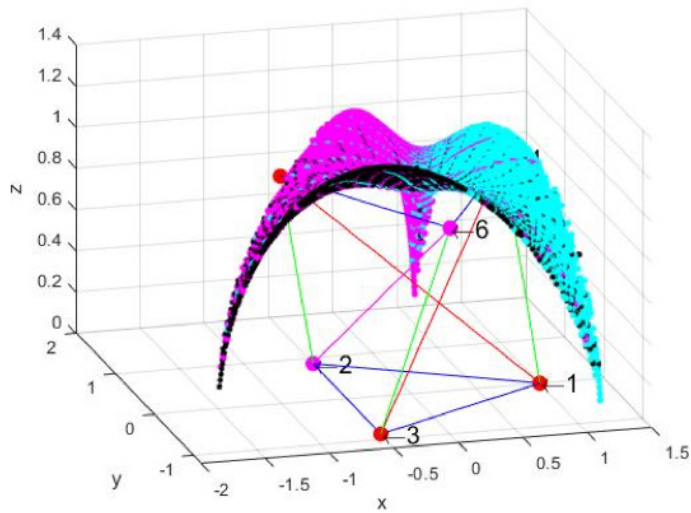

Additive manufacturing of functional hierarchical shape memory alloys structures

PI: Reginald Hamilton, associate professor of engineering science and mechanics

Sponsor: Defense Advanced Research Projects Agency

Summary: The proposed project will develop materials engineering approaches for LDED AM of lamellar shape memory alloy smart material structures (LSMAS) with tunable stiffness for vibration mitigation. The work is in collaboration with sub-contractor Siddhartha Pathak, assistant professor of chemical and materials engineering at the University of Nevada, Reno. Multi-scale thermo-mechanical experimentation and in-situ microstructure and mechanical characterization will bridge local shape memory properties to the performance of the bulk AM build. Data acquisition and analysis protocols will establish critical understandings of the energy loss dependence on the interplay between the geometrical and microstructural hierarchy.

Biomedical Acoustics

Group Summary

The mission of the Biomedical Acoustics group is to understand and apply acoustics toward improving human health. This year, Yun Jing, associate professor of acoustics, joined our group with his two students, bringing our faculty up to 11; the number of students remains fairly constant at approximately 20. Research interests of the group include advanced image processing, ultrasound imaging and therapeutics, photoacoustic imaging, shear wave elastography, drug delivery, and more. Some highlights for 2019-2020 include Julianna Simon receiving an NSF CAREER grant, Yun Jing receiving the IEEE UFFC Star Ambassador Lectureship Award, and Molly Smallcomb completing her master's degree in acoustics.



Group Leader: Julianna Simon
Assistant professor of acoustics and biomedical engineering

Below are some highlights of this group's recent work:

Architected micro-lattices for wide-band vibration attenuation

PI: Yun Jing, associate professor of acoustics

Student: Nikhil JRK Gerard, Department of Mechanical and Aerospace Engineering, North Carolina State University

Summary: Elastic metamaterials are artificial periodic structures that exhibit frequency ranges known as bandgaps, where wave propagation is prohibited. Conventional elastic metamaterials are limited in their bandwidth, since they require impractical mass and size, with respect to the operating wavelength. Additionally, their designs also greatly restrict them from catering more than one functionality. This project introduces a micro-lattice-based metamaterial that can attenuate elastic waves in all directions and over a wide frequency range, alongside possessing the second order functionality of exhibiting a negative Poisson's ratio. Such a thin lightweight material with dual functionality could thus pave way for a variety of unconventional wave-based devices, alongside bolstering the interest for futuristic multi-functional materials.

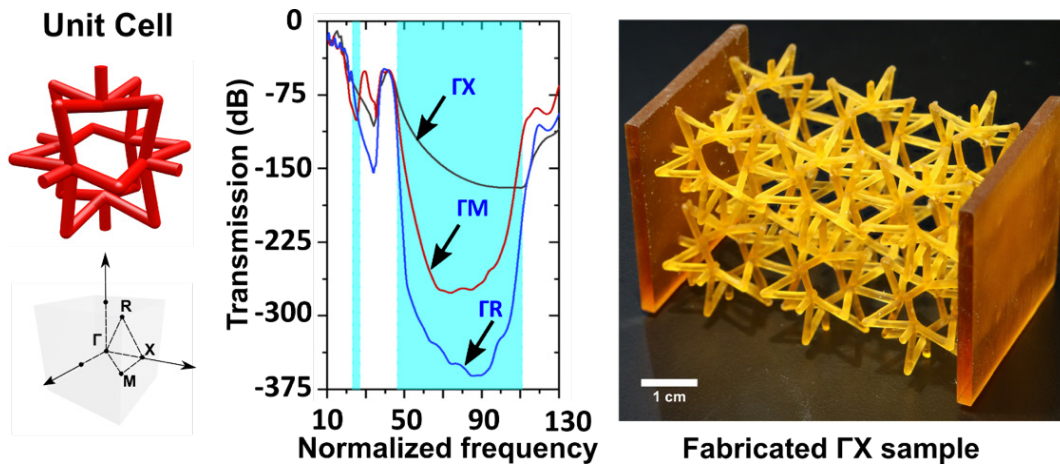

Composite honeycomb metasurface panel for broadband sound absorption

PI: Yun Jing, associate professor of acoustics

Student: Jun Ji, doctoral candidate in acoustics

Project summary: We have recently developed a novel honeycomb composite panel[1] that entails minimum modifications of the conventional honeycomb panel, while drastically improving its sound absorption for low-frequency noise. Our design exploits a perforated face-sheet with non-uniform but periodically arranged pores (**Fig. 1 (a)**). Our preliminary study on a prototype reveals that this seemingly trivial change on the face-sheet can significantly increase the sound absorption of the honeycomb composite panel to over 90% (100% being perfect absorption) over 600-1000 Hz, therefore considerably improving the noise-reduction performance (**Fig. 1 (b)**). Remarkably, this excellent noise-reducing performance is achieved at a thickness of 30 mm which is only 1/20 of the largest working wavelength, meaning such a novel material only occupies a small space. Our technology could potentially revolutionize the way noise is reduced in automobiles, aircrafts, and other places where noise is of significant concern and could have far-reaching environmental and economic impacts.

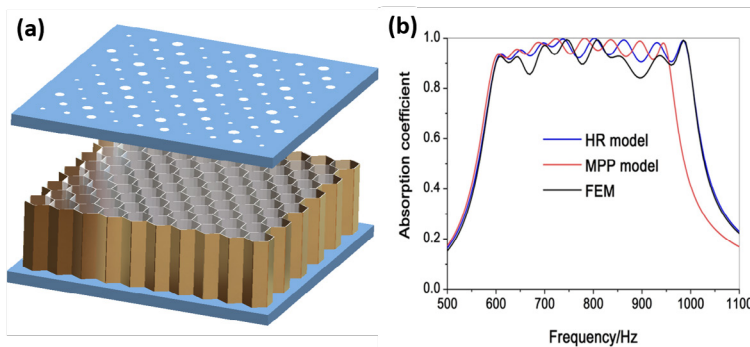

X. Peng, J. Ji, and Y. Jing, "Composite honeycomb metasurface panel for broadband sound absorption," *J. Acoust. Soc. Am.*, vol. 144, no. 4, pp. EL255–EL261, Oct. 2018, doi: 10.1121/1.5055847.

Histotripsy for collagenous tissues: a novel therapeutic approach to tendon injury

Sponsor: National Institutes of Health, National Institute of Biomedical Imaging and Bioengineering

PIs: Juliana Simon, assistant professor of acoustics and biomedical engineering; Co-PI: Meghan Vidt, assistant professor of biomedical engineering and physical medicine and rehabilitation

Students: Molly Smallcomb, doctoral candidate in acoustics; Jacob Elliott, graduate student in acoustics; and Sujata Khandare, doctoral candidate in biomedical engineering

Project Summary: Histotripsy is a therapeutic ultrasound technique that can emulsify soft organs, but highly elastic tissues, like tendon, are resistant to emulsification by histotripsy. Shoulder pain is the third most frequent complaint treated by clinicians, with annual treatment costs exceeding \$7 billion. We propose developing innovative histotripsy protocols to emulsify collagenous tissues, looking specifically at creating microdamage in tendons and promoting a healing response, resulting in the development of a novel clinical treatment option for patients with rotator cuff tear and other tendon injuries.

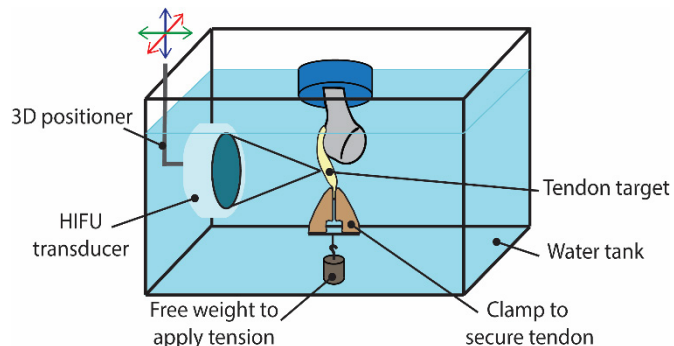

Water tank experiments for ex vivo tendon histotripsy.

Evaluating the distribution of bubble nuclei for acoustic cavitation in tissues

Sponsor: National Science Foundation, Chemical, Bioengineering, Environmental, and Transport Systems

PIs: Juliana Simon, assistant professor of acoustics and biomedical engineering

Students: Eric Rokni, doctoral candidate in acoustics

Project Summary: A major concern in every ultrasound application, such as fetal imaging, is acoustic cavitation, or the creation, oscillation, and collapse of bubbles in an ultrasound field, because bubbles can damage tissues. In clinical ultrasound imagers, the risk is mitigated by requiring machines to display the mechanical index, a measure of the likelihood of cavitation. Yet therapeutic applications of ultrasound leverage acoustic cavitation to break kidney stones or destroy cancerous tissues. Acoustic cavitation arises from bubble nuclei, or microscopic breaks in the molecular structure of liquids. However, no one knows what constitutes a bubble nucleus in human tissues and how these bubble nuclei might be influenced by diseases that deposit unwanted minerals. Thus, the overall goals of the project are to understand what constitutes a bubble nucleus in healthy tissues and develop ultrasound to sensitively detect changes in bubble nuclei that occur when minerals are deposited in tissues.

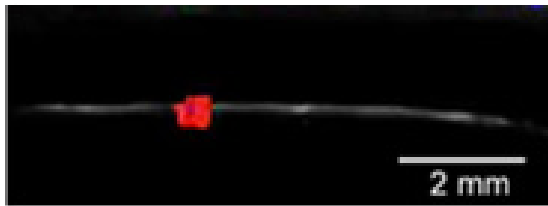

The color Doppler ultrasound twinkling artifact, thought to be caused by stable surface crevice bubbles, can detect minerals immediately after they're deposited by cells.

Flow-Induced Noise



Group Leader: Mike Jonson
 Research associate in aerospace engineering

Measurement of turbulent boundary layer unsteady wall pressures beneath elastomer layers of various thicknesses on a plate

PIs: Robert Campbell, associate research professor of mechanical engineering, and Dean Capone, associate research professor of acoustics

Students: Cory Smith, doctoral candidate in acoustics

Sponsor: Office of Naval Research

Summary: The attenuation of turbulence induced wall pressure fluctuations through elastomer layers is studied experimentally and analytically. Wall pressure statistics are measured downstream from a backward facing step, with no elastomer present and beneath two, three, and four-millimeter-thick elastomers in a water tunnel facility. In the absence of an elastomer layer, the wall pressure spectra, cross-spectra, and velocity statistics measured at the various locations downstream from the backward facing step are in excellent agreement with those reported in the archival literature. The streamwise coherence measured beneath the elastomer layers is higher than that measured in the absence of an elastomer layer, an effect which increases with increasing elastomer thickness. It is speculated that this increase in coherence level is due to the ability of the elastomer to support shear stresses, which effectively increases the area over which an eddy influences the normal stresses measured by the pressure sensors. The high frequency filtering of the elastomers is also observed in the coherence at the smallest streamwise separation. The attenuation of the turbulent boundary layer wall pressure fluctuations through the elastomer layer using an analytical elastomer transfer function is in excellent agreement with the attenuation measured experimentally through all thicknesses of elastomer and at all the free stream velocities at which the experiments are performed.

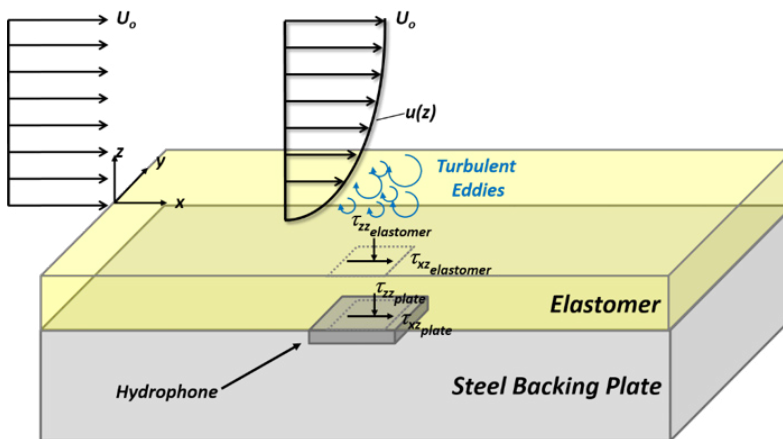

Diagram showing the elastomer-plate system excited by fluctuating TBL wall pressure (i.e., normal stress) and shear stress. The stress τ employs standard tensor notation.

Aeroelastic behavior and flutter mitigation of multi-element wings

PIs: Robert Campbell, associate research professor of mechanical engineering, and Michael Jonson, research associate in aerospace engineering

Student: Auriane Bottai, doctoral candidate in aerospace engineering

Sponsor: NASA (through the University Leadership Initiative Program)

Summary: The objective of the project is to assess the static and dynamic aeroelastic stability of a very high aspect ratio wing. In both cruise and maneuvering flight, such a flexible structure is subject to larger deformation than conventional wings, and therefore linear models may fail to predict the deflection and torsion of the high-aspect ratio wing. Flutter is a dynamic instability that arises when aerodynamics and structural deformation sustain each other. The wing undergoes complex coupled oscillations in torsion, in-plane and out-of-plane bending, which may lead to structural fatigue and failure. Studies have shown that flutter is driven by nonlinear aerodynamics and nonlinear elastic behavior. The current research focuses on a high-aspect ratio truss-braced, Slotted-Natural-Laminar Flow (TB-SNLF) wing and is split into analytic and numerical studies. The analytic work investigates the modal characteristics of slender wing, with and without truss, under linear and stalled aerodynamics. Finite element method will next be employed to include the geometric and structural features of the wing, as well as airfoil characteristics, in the flutter stability analysis.

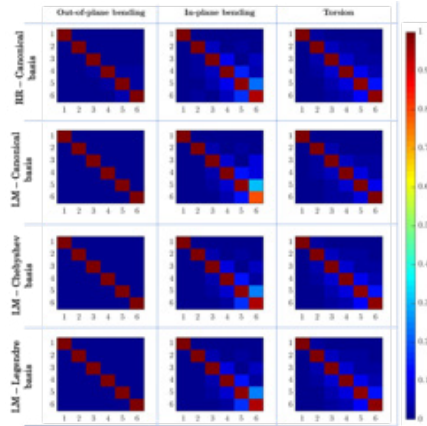

Symmetry methods for axisymmetric turbulent flow

PIs: Zachary Berger, assistant research professor in the Applied Research Lab; Ryan Murray; Michael Jonson, research associate in aerospace engineering; and Amanda Hanford, assistant research professor in acoustics

Sponsor: Penn State Applied Research Laboratory

Summary: Modeling turbulence is a central problem in modern fluid mechanics and engineering, and in order to make advances in this field, turbulent flow must be better understood and modeled accordingly. This research is interested in looking at turbulence from an axisymmetric viewpoint, which means that there are symmetries identifiable with respect to some axis in a flow with a preferred direction. The hope is to obtain simplified forms of second order Reynolds Averaged Navier-Stokes (RANS) and Euler equations in cylindrical coordinates by finding families of invariant solutions. Using a well-established, classical method called Lie theory, transformations and symmetries can be solved for, which allows us to come up with these solutions/simpler models. Another important aspect of this research is obtaining experimental PIV data in a fully developed turbulent pipe to validate the mathematical findings of the symmetry analysis. Two-point correlations will be extracted from the PIV data and used to compare with what was found through the mathematical analysis and to obtain scaling laws. Thus far, our research has identified several symmetries deemed relevant to the flow and collected planar PIV data from the core region of a turbulent pipe. The facility used was the glycerin tunnel at the Penn State Applied Research Lab, which provides a fully developed, axisymmetric turbulent flow. We are now in the process of analyzing our PIV data to extract the two-point correlations, which is vital to validating our model.

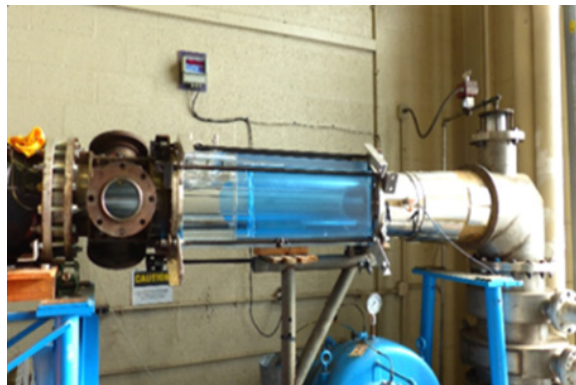

ARL Glycerin Tunnel used to collect PIV data

Acoustic control of a maneuverable marine hydrokinetic cycloturbine

Sponsor: Ocean Renewable Power Company, U.S. Department of Energy ARPA-E

PIs: Margalit Goldschmidt, doctoral candidate in aerospace engineering; Michael Jonson, research associate in aerospace engineering; and Joseph Horn, professor of aerospace engineering

Summary: Marine hydrokinetic (MHK) cycloturbines exploit tidal currents to generate sustainable electric power. Because of the harsh marine environment, MHK cycloturbines require frequent maintenance and repair, which for current systems necessitates the use of a ship, making the process difficult and costly. A novel MHK cycloturbine system has been designed that uses pitching foils for maneuver, potentially circumventing the costs and difficulties associated with deployment and repairs. The vehicle fatigue is decreased, and the vehicle's acoustic signature underwater is reduced by design of a novel acoustic controller. This controller specifically reduces the tonal noise at blade rate frequency.

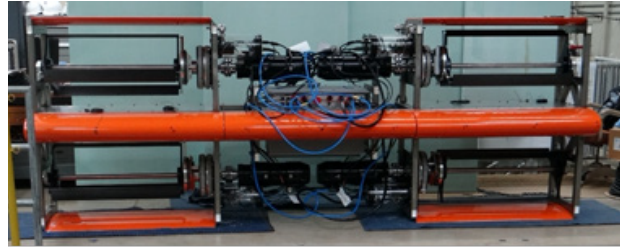

Each turbine foil radiates noise equivalent to an acoustic dipole at multiples of blade rate frequency, and so the vehicle is modelled as an acoustic multipole. At blade rate frequency, the turbine size compared to its acoustic wavelength allows for the entire vehicle to be treated as a compact source. The effect of turbine clocking on directivity and sound power is shown. The effects of the designed controller to reduce tonal noise at blade rate frequency and multiples are verified experimentally through testing in the Penn State Applied Research Laboratory's reverberant tank facility. Fixing a subscale demonstrator (SSD) to a reaction frame provides the ability to measure the integrated loads using load cells. The radiated sound pressure is computed for the load cell data obtained. Acoustic control is implemented using the turbine RPM: turbines are clocked by slowing one turbine relative to another for a short period of time.

Impact of high-temperature effects on the aerothermoelastic behavior of composite skin panels in hypersonic flow

PI: Daning Huang, assistant professor of aerospace engineering

Student: Aravindh Sadagopan, doctoral candidate in aerospace engineering

Summary: This study investigates the impact of the high-temperature effect, especially the real gas effect and the chemical reactions, on hypersonic aerothermodynamic solutions and the aerothermoelastic behavior of a typical skin panel in hypersonic flow. First, several computational fluid dynamics codes that were developed in significantly different ways were benchmarked and compared for hypersonic aerothermodynamics, emphasizing the impact of high-temperature effects as well as turbulence modeling on heat flux prediction. Subsequently, a reduced-order model (ROM) for hypersonic aerothermal loads accounting for the high-temperature effect is developed. Particularly, a ROM correction approach for high-temperature effect was presented, so that a ROM constructed based on the perfect gas assumption can generate fluid solutions that account for the real gas effect with reasonable accuracy. Finally, the new fluid ROM was applied to study the impact of the high-temperature effect on the aerothermoelastic response of a hypersonic skin panel, with an emphasis on its stability boundary.

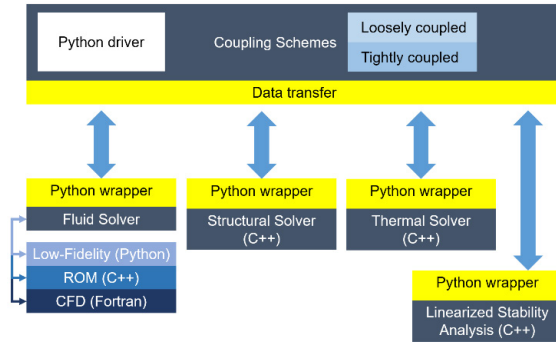

Code structure of the extended hypersonic aerothermoelastic simulation framework

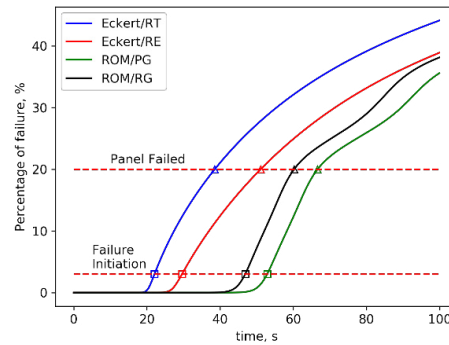

Percentage of upper surface area of failed region, highlighting the erroneous trend of simplistic aerothermal models (Eckert) when compared to higher-fidelity models (ROM).

Propagation and Radiation

Group Summary

The mission of the Propagation and Radiation Technical Group is to develop a new understanding of how sound is generated and propagated in realistic environments, to translate this understanding into techniques for making decisions about the use and control of sound, for making inferences about sources and the environment, and to apply this understanding to the design of devices and systems. Understanding the perception of sound by individuals and estimating noise impacts on people are two of the primary applications of the research.

Penn State has continued to participate in the FAA Center of Excellence in Alternative Jet Fuels and the Environment. As part of the Aviation Sustainability CENter (ASCENT), Sparrow is continuing to work on multiple FAA ASCENT projects as well as serving as the overall ASCENT lead investigator at Penn State. Some of the ongoing research has focused on understanding and



Group Leader: Victor Sparrow
Director of the Graduate Program in Acoustics

overcoming the limitations of current FAA noise tools, particularly in improving the propagation modeling for noise around airports, including atmospheric profile models. Further work has centered on improving our understanding of the limitations of metrics for sonic booms and to develop methods to potentially certify future civilian supersonic aircraft. Such certification methods might include signal processing to remove the effects of atmospheric turbulence from measured sonic boom signatures.

Below are some highlights of this group's recent work:

Improved sound mapping tools using Python and ArcGIS

PIs: Victor Sparrow, director of the Graduate Program in Acoustics, and Peter Newman, department head of recreation, park, and tourism management

Student: Adwait Ambaskar, graduate student in acoustics

Sponsor: U.S. National Park Service

Summary: A new sound mapping tool recently was developed by Nathan Tipton, a recent graduate student in the Penn State Graduate Program in Acoustics. The major purpose of the tool is to create a truly open source outdoor sound propagation model compatible (but not dependent on) an outside Geographic Information System (GIS). The model was written in Python and developed using algorithms from ISO 9613-2, an international standard for attenuation of sound during propagation outdoors. The standard accounts for uneven terrain, atmospheric absorption, screening, wind effects, and ground effects. Given sound source inputs and locations over an input digital elevation map, GIS-compatible file types of spatially explicit sound pressure level predictions were produced by this model. The current model was tested using simple simulated terrains and has produced preliminary results using real terrain data and natural gas compressor noise as the sound source. Current efforts are being made to improve the capabilities of the sound propagation model by being able to model screening effects more realistically, being able to include multiple sources of sound, and including effects in outdoor sound propagation resulting from wind and ground effects. Results of this work offer a preliminary version of an open source outdoor sound predictive tool with a capability of mapping visitor-experiences for both state parks and U.S. national parks.

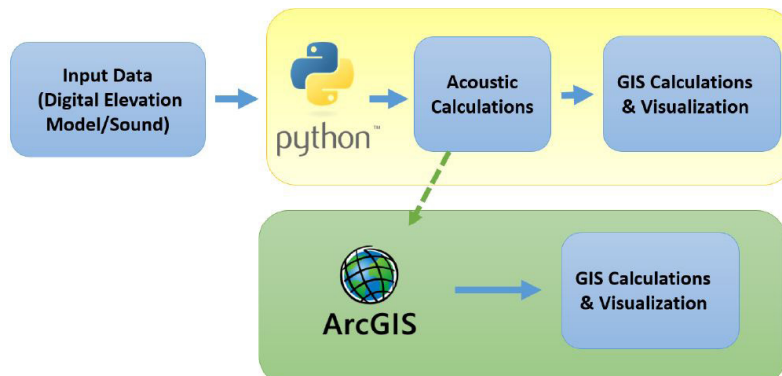

Uncertainty and validation for aircraft noise propagation predictions

PI: Victor Sparrow, director of the Graduate Program in Acoustics

Student: Harshal P. Patankar, doctoral candidate in acoustics

Sponsor: FAA

Summary: To comply with noise regulations and to plan infrastructure around airports, there is a need to accurately predict aircraft noise levels. Even when high fidelity noise propagation models are used, the accuracy of noise level predictions can be affected by uncertainty in the inputs to the model. The typical inputs include the model for aircraft noise source and the model for noise propagation path (meteorological conditions and ground conditions). The main focus of this project is to assess the effect of meteorological uncertainties on the noise levels received near the ground. The methodology developed for assessing the effect of meteorological uncertainties will be validated with the help of real world aircraft noise measurements from the BANOERAC data—BANOERAC stands for “Background noise level and noise levels from en-route aircraft,” a project initiated by the European Union Aviation Safety Agency contracted to ANOTEC Consulting, S.L. This data includes aircraft noise measurements near the ground, aircraft tracking data, and limited meteorological data. The data will be used to assess the relative importance of meteorological uncertainties and the uncertainties in modeling the aircraft noise source, when predicting the aircraft noise received near the ground. [This work was funded by the U.S. Federal Aviation Administration (FAA) Office of Environment and Energy as a part of ASCENT Project 40. Any opinions, findings, and conclusions or recommendations expressed in this material are those of the authors and do not necessarily reflect the views of the FAA or other ASCENT Sponsors.]

Multi-year global investigation of sonic boom propagation and loudness

PI: Victor Sparrow, director of the Graduate Program in Acoustics

Student: William Doebler, graduate student in acoustics

Sponsor: NASA Advanced Degree Program

Summary: Overland civil supersonic flight has been prohibited for over 45 years due in part to the loudness of sonic booms. Recent advances in aircraft design indicate that quiet supersonic flight may be achievable with loudness on the order of distant thunder. The Federal Aviation Administration has recently been charged by Congress to reassess the supersonic flight prohibition and to investigate the possibility of determining new supersonic aircraft certification standards, including noise standards. The noise standards would include setting the loudness limits of sonic booms from commercial aircraft. Supersonic flight is particularly effective for reducing travel times between distant destinations, so noise limits would ideally be effective globally. Macroscopic atmospheric effects on sound differ by season and geographical region. Thus, the loudness of an aircraft’s sonic boom may differ in various seasons and climates. By simulating propagation of sonic booms from several existing and concept aircraft through global databases of atmospheric profiles, it is possible to statistically evaluate and quantify the effectiveness of both aircraft boom levels and potential noise limits.

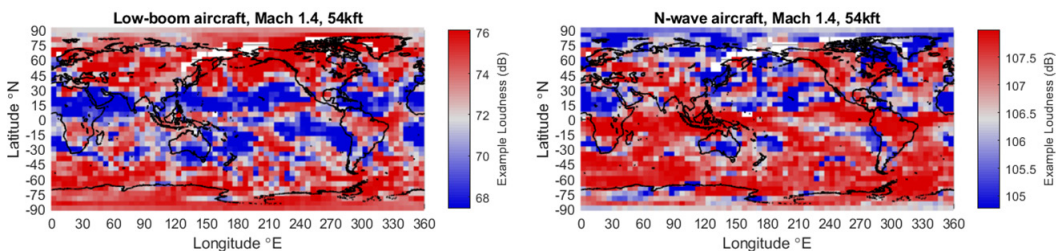

Figure 2. Example sonic boom ground loudness predictions from two different aircraft nearfields propagated through Global Forecast System atmospheric profiles at a single timestamp.

Identification of noise acceptance onset for noise certification standards of supersonic airplanes

PI: Victor Sparrow, director of the Graduate Program in Acoustics

Student: Joshua Kapcsos, doctoral candidate in acoustics

Sponsor: FAA

Summary: National aviation authorities are moving forward to develop noise certification standards for low-boom supersonic airplanes. In order to reconsider 14 CFR part 91.817, which prohibits civil supersonic flight over land, research is conducted to advance the understanding of the appropriateness of sonic boom metrics for different atmospheric conditions. The work undertaken required heavy use of the PCBoom sonic boom propagation software maintained by NASA. Atmospheric profiles affecting the potential approval of civil supersonic flight over land for low boom aircraft were investigated, such as ambient pressure, temperature, relative humidity, and wind, as functions of height. It was concluded that the software does not have difficulty processing discontinuities due to temperature smoothing, a feature of real atmospheres. Dramatic shifts in molar concentration of water vapor were shown to have small impact on boom levels. Because wind convects sound, wind profiles were added to an otherwise unchanged atmosphere to observe its effect on loudness in general. The image provided by Luke Wade, a graduate research assistant previously working on the project, shows that winds along the flight direction, headwind or tailwind, can affect the boom levels on the ground. Work is ongoing to explore the effect of winds in arbitrary directions and of the effects of atmospheric turbulence. [This work was funded by the US Federal Aviation Administration (FAA) Office of Environment and Energy as a part of ASCENT Project 41. Any opinions, findings, and conclusions or recommendations expressed in this material are those of the authors and do not necessarily reflect the views of the FAA or other ASCENT sponsors.]

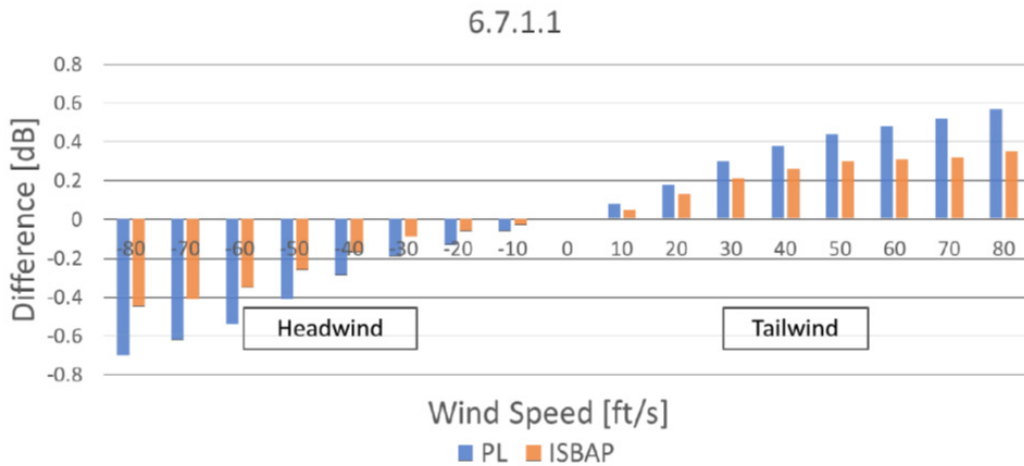

Corrected three-dimensional ray theory for the prediction of Mach cutoff sonic boom

Sponsor: FAA

Principal Investigator: Victor Sparrow, director of the Graduate Program in Acoustics

Student: Zhendong Huang, doctoral candidate in acoustics

Summary: Mach cutoff flight is achieved when a supersonic airplane operates in a narrow speed-altitude envelope just above Mach 1, intending that no sonic boom directly impacts the ground. In this research, a 3D ray-tracing algorithm has been developed for the acoustical model of Mach cutoff flight, which can read in realistic atmospheric data including arbitrary speed of sound variations as well as arbitrary 3D winds. Ray-tracing simulations were then run by using High-Resolution Rapid Refresh (HRRR) data for the atmosphere combined with three busiest air routes, two flight altitudes, two safety margins, and 80 realistic atmospheric profiles in the year of 2017, to enable statistical prediction of the viability of Mach cutoff flight. This research shows that Mach cutoff operations will very often work if the atmosphere is sufficiently well known. Either the seasonal or daily variation in the atmosphere may significantly affect how fast an aircraft can fly under Mach cutoff. [This work was funded by the US Federal Aviation Administration (FAA) Office of Environment and Energy as a part of ASCENT Project 42. Any opinions, findings, and conclusions or recommendations expressed in this material are those of the authors and do not necessarily reflect the views of the FAA or other ASCENT Sponsors.]

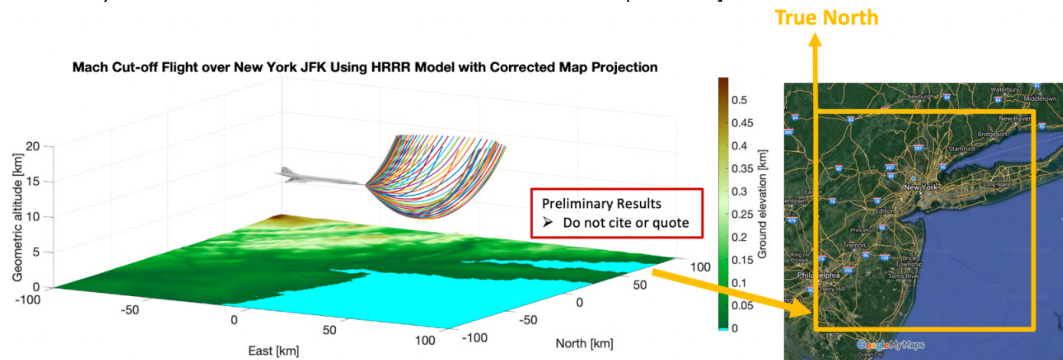

Ray diagram for an eastbound flight over New York JFK, cruising at the cutoff Mach number.

Michelle Vigeant continues to lead the Sound Perception and Room Acoustics Laboratory (SPRAL). Vigeant is currently pursuing research in four areas: (1) concert hall acoustics, (2) virtual acoustic reproduction over headphones, (3) aircraft noise, and (4) office noise.

A spherical microphone and compact loudspeaker array measurement database for the study of concert hall preference

(can be accessed at sites.psu.edu/spral/)

PI: Michelle Vigeant, associate professor of acoustics

Student: Matthew Neal, recent graduated doctoral student in acoustics

Sponsor: National Science Foundation

Summary: The goal of this research was to study concert hall perception using spherical array processing techniques in a wide variety of real concert halls. For the study, the concert hall orchestral research database, or CHORDatabase, was generated, consisting of spherical microphone and compact spherical loudspeaker array (CSLA) room impulse response (RIR) measurements in 21 concert halls. The concert halls in the database include a wide variety in shape, size, reverberance, and geography, including 15 North American and six European halls. A subjective study investigated which factors were most important regarding concert hall perception and preference. A factor analysis revealed three to four factors of importance, relating to clarity,

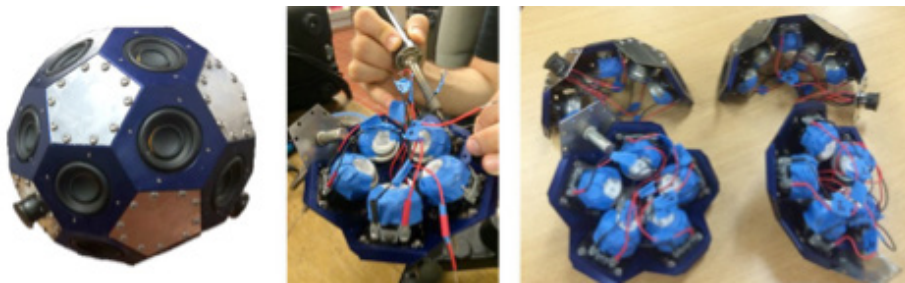

20-sided compact, spherical loudspeaker array (CSLA) used to radiate orchestral instrument directional patterns for room impulse responses in 21 concert halls.

Investigating single value frequency average measures to predict reverberance, clarity, and preference in concert halls using auralizations

PI: Michelle Vigeant, associate professor of acoustics

Student: Fernando del Solar, doctoral candidate in acoustics

Summary: The project is focused on finding more information about current concert hall acoustic measures. Several objective measures have been proposed in the past to describe the acoustics of a concert hall. Still, more information is needed about these existing measures. Using the stimuli from the CHORDatabase, subjective testing is being conducted in Penn State's Auralization and Reproduction of Acoustic-Sound fields (AURAS) facility, to determine just noticeable differences (JNDs), single value frequency-averages, and preferred values for concert hall acoustics metrics.

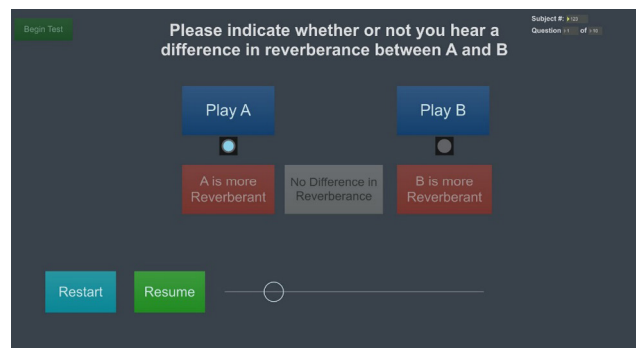

Subjective testing interface for just noticeable difference (JND) study.

Connecting spatial perception with features of the head-related transfer function

PI: Michelle Vigeant, associate professor of acoustics

Student: Nicholas Ortega, doctoral candidate in acoustics

Sponsor: College of Engineering Fellowship and Sloan Scholarship

Summary: Head-related transfer functions (HRTFs) contain the necessary information to synthesize binaural audio for headphones, digitally inserting the effects of the head and body that headphones remove. Experimental design is underway for a study that will link the numerical data for the HRTF with spatial perception of sounds synthesized using the same HRTFs. Existing software tools from Aalto University have been combined with a unity-based virtual reality program to produce headphone-based audio that uses the information from the HRTF and motion tracking. The setup uses the Oculus Rift system for visuals, interfacing, and motions tracking. Max MSP is used in conjunction with Aalto's SPARTA VSTs to synthesize the stimuli. Stimuli and question sets are now being developed to target which spatial regions and frequencies are tied to various perceptual aspects, and a first perceptual study is scheduled to begin this fall.

HRTF Magnitude, 1 kHz, Left Ear

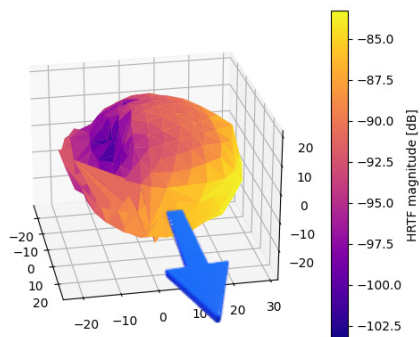

Measured Interaural Time Delay

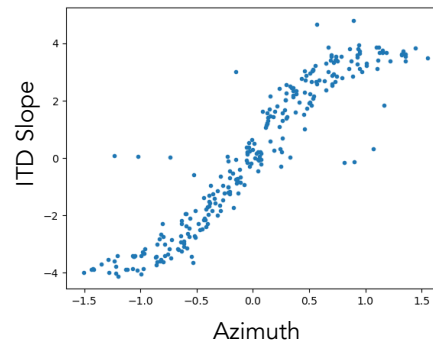

A Penn State student's HRTF measured at the Wright-Patterson Air Force Research Laboratory (AFRL)
Left: HRTF magnitude (left ear, 1000 Hz) is plotted by look direction, with radius and color representing the magnitude. Subject is facing toward the reader. The plot illustrates the head's shadow, blocking sound on the right from the left ear. Right: measured interaural time delays plotted by azimuth. The plot demonstrates the near-total dependence of this important auditory cue on azimuth.

Computationally simplifying room acoustic auralizations while maintaining perceptual fidelity

PI: Michelle Vigeant, associate professor of acoustics

Student: Zane Rusk, doctoral candidate in architectural engineering

Sponsor: Graduate Assistance in Areas of National Need (GAANN) Fellowship

Summary: This project seeks to explore the degree to which room acoustic auralizations can be reduced in physical accuracy while still maintaining perceptual realism and immersion. Models that are only as computationally complex as required for perception will be better suited for use in applications such as virtual reality or iterative design processes. At the current phase, perceptual equivalence between binaural head room impulse responses (BRIRs) as measured with a Brüel & Kjær Type 4100-D head and torso simulator (HATS) [see photo] and binaurally-rendered spatial room impulse responses (SRIRs) measured with a spherical microphone array (Eigenmike em32) [see photo] is being evaluated. BRIRs serve as a baseline for human perception while SRIRs can be manipulated to represent a room with varying accuracy.



Perceived annoyance of Mach-cutoff flight ground signatures relative to common transportation sounds

PI: Michelle Vigeant, associate professor of acoustics

Student: Jonathan Broyles, graduate student in acoustics

Sponsor: FAA

Summary: A potential operational solution to sonic-booms over land is Mach-cutoff flight, which in ideal atmospheric conditions, refracts the sonic-boom upwards thus creating an evanescent sound-field below. The goal of this work was to compare the perceived degree of annoyance of the evanescent signatures to common transportation sounds. Mach-cutoff flight stimuli were generated using recordings from NASA's Farfield Investigation of No-boom Thresholds (FaINT) dataset, and transportation sounds were recorded at local interstates, railroads, and airports. Subjective testing was conducted to investigate annoyance and preference using individual comparisons with an absolute scale and multiple comparisons with a relative scale. In general, the Mach-cutoff signatures were found to be less annoying than the other three types of transportation noise evaluated.

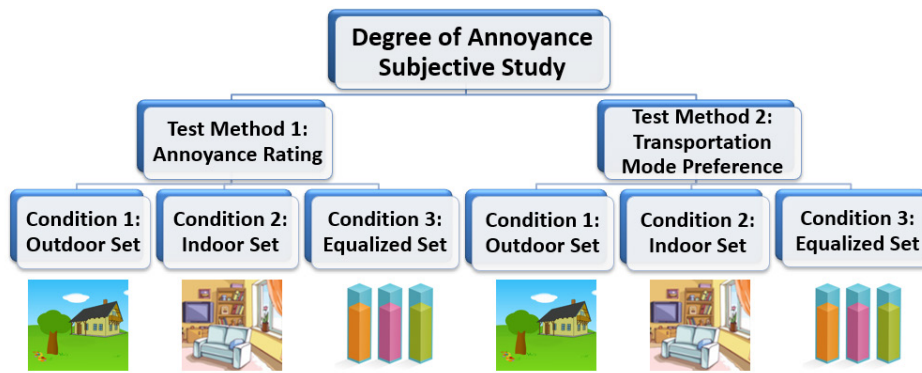

Overview of the experimental design to evaluate the relative annoyance of Mach-cutoff signatures compared to road, rail, and subsonic traffic sounds.

Tasks to evaluate the effect of office noise on cognitive function

PI: Michelle Vigeant, associate professor of acoustics

Student: Zhi Zhou, graduate student in acoustics

Sponsor: GNResound

Summary: A series of tasks are currently being evaluated to evaluate the effects of noise on cognitive function, specifically working memory, reasoning, attention, and planning. Participants will be exposed to two different background noise environments—one that is recorded HVAC noise and one that has spatially distributed, typical, intermittent office sounds, e.g. talking, phone ringing, etc. The testing will take place in the AURAS facility. The cognitive tasks under consideration are the digit span test (participants must recall a series of eight numbers), grammatical reasoning (participants must read a sentence and respond true/false), attention network test (participants must identify the direction of an arrow amongst distracting information), and the Tower of London (participants must arrange a series of numbers in the correct order).

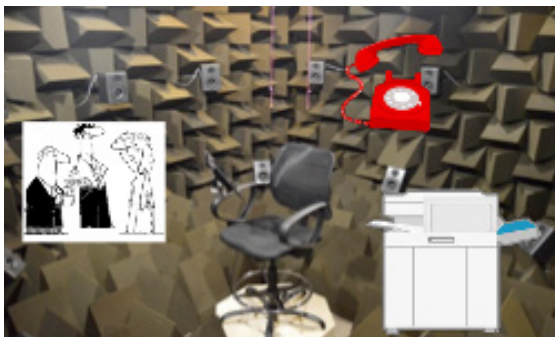

The Auralization and Reproduction of Acoustic Sound-fields (AURAS) facility at Penn State used to reproduce realistic 3D sound fields. For this study, intermittent sounds sources are placed at different locations around the listener to simulate an open-plan office environment.

Rotorcraft Acoustics and Dynamics

Group Summary

The Penn State's CAV Rotorcraft Acoustics and Dynamics Group continues to be at the core of our Vertical Lift Research Center. Penn State is home to one of only three NRTC Vertical Lift Research Centers of Excellence (VLRCE) in the country. In the summer of 2016, our center was successfully renewed for another five years. As part of our new program, we started 14 new research projects. We are grateful to our industry partners at LORD Corporation, Bell, and Sikorsky for their support of our proposal. The center currently supports more than 50 full-time graduate students and involves more than 25 Penn State faculty members in a wide range of technologies supporting rotary-wing aircraft. Seeking cost and weight efficient solutions to lower interior noise and vibration, we have a suite of research tasks and reduced exterior noise signatures is a high priority. We have experienced particular growth in programs focused on structural health monitoring, pneumatic ice protection systems, and naval-oriented flight dynamics/controls. Our various research projects are presently supported by the U.S. Army, U.S. Navy, NASA, and the industry sector—including large airframe manufacturers, sub-system vendors, and numerous small high- technology companies. Emphasis areas include: advanced flight controls and vehicle dynamics simulation, interactional source noise, acoustical scattering of rotor noise, gearbox noise, active and passive airframe vibration control, crashworthy and impact



Group Leader: Edward Smith
Professor of aerospace engineering

resistant structures, anti-icing systems, variable speed rotors, structural health monitoring, and rotor loads monitoring. Several new facilities have recently been brought online. The Adverse Environment Rotor Test Stand (rotor icing chamber) has proven to be a versatile and heavily used facility. Additionally, experimental testing has also been recently conducted for new compact energy harvesters, tiltrotor whirl flutter wind tunnel models, rotor hub-flow visualizations, and new rotor system dampers. Our annual Rotorcraft Technology Short Course will be offered for the 53rd consecutive year on Aug. 10-14. Topics in the comprehensive course include rotorcraft aerodynamics, dynamics, acoustics, composite structures, flight controls and propulsion. For more information, please visit rotary-wing.outreach.psu.edu/.

Below are some highlights of this group's recent work:

Testing of fluidic flexible matrix composites (F2MC) damped vibration absorber for stiff in-plane hingeless rotorcraft blades

PIs: Edward Smith, professor in aerospace engineering, and Chris Rahn, J. Lee Everett Professor of mechanical engineering and associate dean for innovation

Student: Valentin Lanari, graduate student in aerospace engineering, and Michael Trowbridge, graduate student in mechanical engineering

Sponsor: U.S. Army, U.S. Navy, and NASA

Summary: F2MC tubes are integrated into the spar of a scaled rigid rotor blade along with a tuned fluidic circuit. The F2MC tube is strained by the blade's chordwise bending vibration, pumping fluid within the circuit and dissipating energy. Both model predictions and benchtop experiments agree on an increase to 10% damping ratio from a 0.5% baseline. Rotating environment testing at Penn State's Adverse Environment Rotor Test Stand (AERTS) have been conducted and challenging dynamic issues of the setup interacting with the rotor stand are being solved.

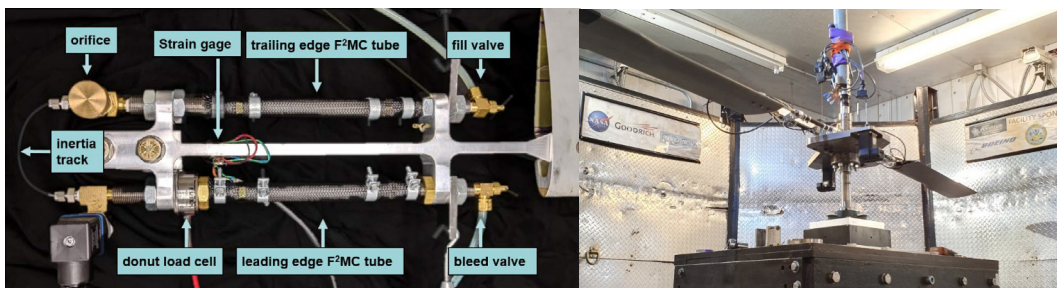

Enhanced damping for high-speed rigid rotors via tailored hybrid nanocomposites

PIs: Chuck Bakis, distinguished professor of engineering science and mechanics, and Edward Smith, professor of aerospace engineering

Students: Keerti Prakash, doctoral candidate in aerospace engineering

Sponsors: U.S. Army VLRCOE and LORD Corp.

Summary: Traditional lag dampers used in rotorcraft are ineffective in providing adequate damping for high-speed coaxial compound rotorcraft which have rigid, hingeless blades. Carbon nanotubes (CNTs) have shown the potential to offer an intrinsic passive damping solution for such applications. In the past year, we evaluated the effectiveness of using CNTs to provide structural damping in a laminated fiber reinforced composite beam. Baseline composite and hybrid nanocomposite beams with $[\pm 45/0]_s$ stacking sequence were fabricated. CNT interlayers were placed between the continuous carbon-fiber/resin plies within the hybrid composite. The volume fraction of CNTs added to the composite was 1%. The fabricated beams were subjected to free and forced vibration tests. Damping from CNTs was observed to be strain dependent. CNTs are believed to slip once a critical value of strain is reached and the slippage contributes to the composite damping. The damping ratio contribution from CNT interlayers was up to ~2.2% for free vibration tests and up to ~3.7% for forced vibration tests. The damping augmentation is significant as the baseline composite damping ratio is ~0.2%. An in-house structural micromechanical model, incorporating the CNT parameters, such as aspect ratio and critical shear stress, was able to reproduce the damping trends seen in the experiments. To investigate the effect of centrifugal forces on a nanocomposite beam, a rotating test has been conceptualized and fabricated. The test setup is designed for wireless data acquisition using Bluetooth. The tests are currently being conducted.

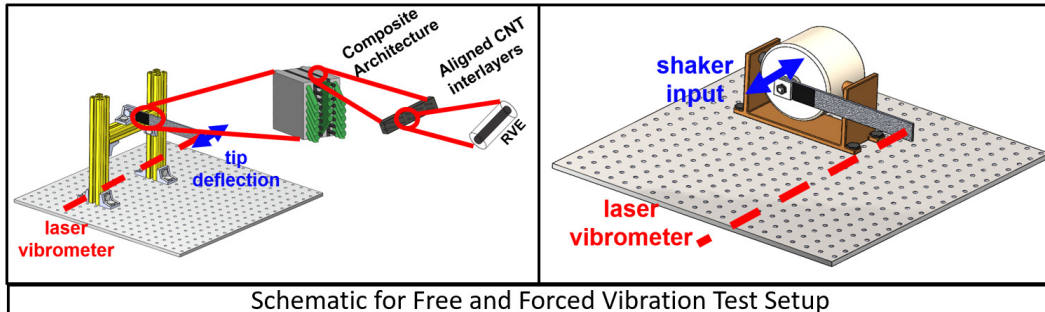

Schematic for Free and Forced Vibration Test Setup

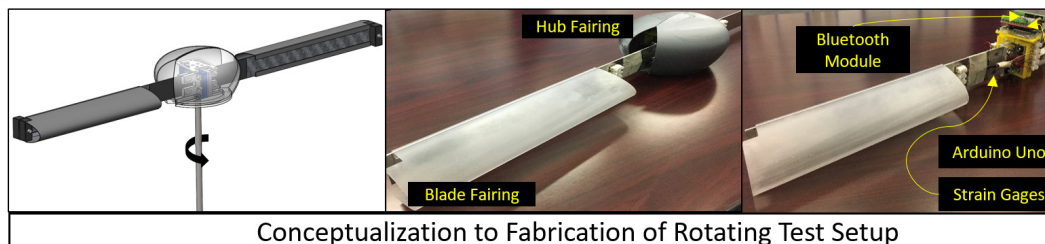

Conceptualization to Fabrication of Rotating Test Setup

Identifying trunnion bearing manufacturing defects with acoustic emission testing

PI: Edward Smith, professor of aerospace engineering, and Clark Moose, research and development in the Applied Research Lab

Student: Daniel Jaep, graduate student in mechanical engineering

Sponsor: ITT

Summary: This project involves using acoustic emission to test for manufacturing defects in center trunnion bearings for main rotor transmission mount. A peripheral device was designed and fabricated to allow for load and extension data from the test machine to be fully synced and integrated with acoustic emission data acquisition system and software. Trunnion bearings and double lap shear (DLS) coupons with simplified geometry have been tested thus far. We are currently investigating the use of finite element analysis to predict wave propagation in specimen and ideal transducer placement.

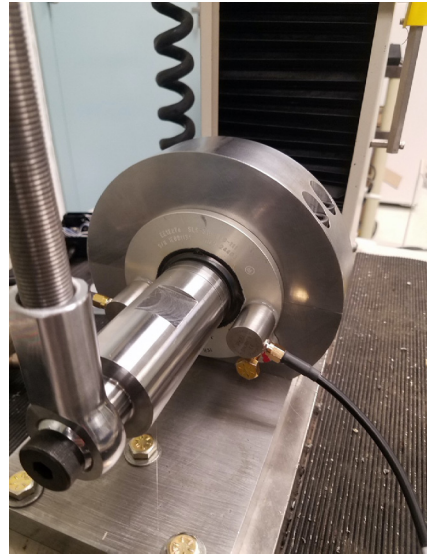

Experimental Setup for collecting Acoustic Emission Data

Fluid-free tuned vibration absorber

PIs: Edward Smith, professor of aerospace engineering, and Chris Rahn, J. Lee Everett Professor of Mechanical Engineering and associate dean for innovation

Student: George Rai, graduate student in mechanical engineering

Sponsor: LORD Corporation

Summary: Fluid-elastic vibration absorbers typically trade improved isolation, performance, and footprint over strictly elastomeric or other typical mechanical designs for a more complex manufacturing process and a potential increase in temperature sensitivity. This project investigates the feasibility of a fluid-free vibration absorber that is able to match the performance of a fluid-filled device. The design is inspired by the classic dynamic antiresonant vibration isolator, where a lever-tip mass combination can cancel the vibrations on the isolated mass.

Fundamental study of coaxial rotor aeroacoustics

PI: Ken Brentner, professor of aerospace engineering

Student: Kalki Sharma, doctoral candidate in aerospace engineering

Sponsor: U.S. Army VLRCOE

Summary: Coaxial rotors are being developed for high-speed rotorcraft. Fundamental computational simulations are required to understand the aeroacoustic behavior of these complex systems. The upper rotors are colored blue and the lower rotors are colored green. Overall sound pressure level from the 10th to 50th blade harmonic is presented on a hemispherical grid. The source of noise is the coaxial rotor system (black disks), which is traveling at 100 knots in the positive x-direction at varying shaft tilts (negative for forward tilt; positive for rearward tilt). The tilt of the rotor shaft influences the severity of the interactions between the closely spaced rotors and has an impact on the strength and direction of the rotor system's mid-frequency range sound pressure level.

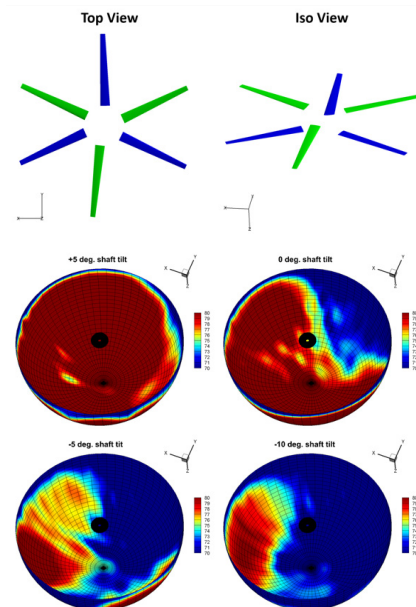

Computationally efficient simulations for co-axial rotor performance

PI: Sven Schmitz, associate professor of aerospace engineering
Student: Jason Cornelius, doctoral candidate in aerospace engineering
Sponsor: National Science Foundation

Summary: The mixing-plane approach, a method first implemented in turbomachinery, has been applied to a coaxial rotor in hover. The approach allows for simplifying assumptions such as periodic boundaries, rotating reference frames, and a steady solution of the Navier-Stokes equations. This allows for a dramatic decrease in computational time while still producing a high-fidelity result.

This image shows the two resolved blades of the coaxial rotor with the mixing-plane approach. A cut plane shows the velocity magnitude around and beneath the rotors. The blade tip vortexes and the contraction of the wake can be observed.

Below is a graphic of the baseline time-accurate simulation that was used to measure the accuracy of the mixing-plane approach. The model setup and solution method follow the conventional state-of-the-art best practices in the context of an unsteady Reynolds-averaged Navier-Stokes simulation.

The mixing-plane approach yielded a 430 times reduction in computational time, or more than two orders of magnitude over the conventional time-accurate approach. The largest deviation of rotor thrust and torque between the two models is less than 2%, which shows the feasibility of the mixing-plane approach as a high-fidelity analysis method with low computational expense. Time accurate CFD solutions are also being utilized to explore oscillatory loads of rigid coaxial rotors in edgewise flight.

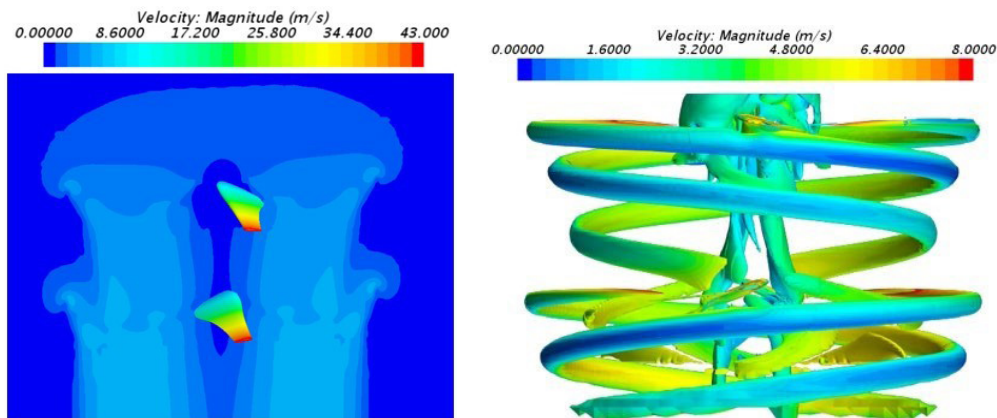

Design, analysis, and experimental testing of a compact, high reduction ratio and low noise Pericyclic transmissions

PIs: Edward Smith, professor of aerospace engineering, R. Bill, L. Chiang, H. DeSmidt

Students: Tanmay Mathur, doctoral candidate in mechanical engineering

Sponsor: U.S. Army VLRCOE

Summary: Based on component level and system level design analysis tools developed in the past years, an internally driven torque sharing, twin configuration, Pericyclic drive concept has been developed to operate within allowable operating conditions of the NASA Glenn Transmission Test rig. In this work, design refinements and additional features required for successful fabrication, assembly, and testing of the prototype transmission are described. Thereafter, the weights and inertia of the components are updated in the design analysis to predict performance characteristics of the test article such as efficiency, bearing loads and life, tooth loads, lubrication requirements, and component stiffness. Some of these results will be validated from test runs of the prototype scheduled for the near future.

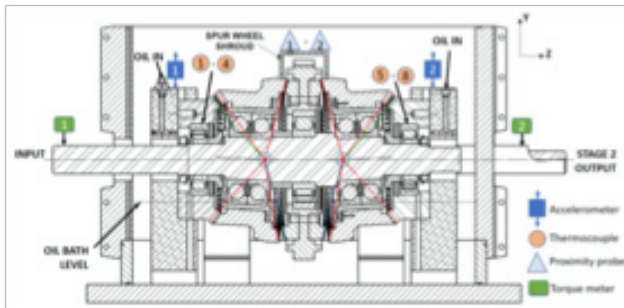

Civil certification noise prediction tools

PI: Ken Brentner, professor of aerospace engineering

Student: Abhishek Jain, doctoral recipient in mechanical engineering

Sponsor: Bell Helicopter TEXTRON

Experimental measurement of ice crystal dynamics

PI: Jose Palacios, associate professor of aerospace engineering

Student: Sihong Yan, doctoral candidate in aerospace engineering

Sponsor: NASA

Load alleviation control design using high order dynamic models

PI: Joe Horn, professor of aerospace engineering

Student: Umberto Saetti, doctoral candidate in aerospace engineering

Sponsor: U.S. Army VLRCOE

Fundamental investigations into future low-drag single/and co-axial rotor hub systems

PI: Sven Schmitz, associate professor of aerospace engineering

Student: Charles Tierney, doctoral candidate in aerospace engineering

Sponsor: U.S. Army VLRCOE

Structural Vibration and Acoustics

Group Summary

The Structural Vibration and Acoustics Technical Group investigates how structures vibrate and radiate sound. We develop novel methods to analyze, measure, and control structural vibrations and radiated noise.



Group Leader: Steve Hambric
Research professor in acoustics

Below are some highlights of this group's recent work:

Experimental and computational analysis of thermal and dynamic performance of hybrid gears under normal and loss-of-lubrication operation

PIs: Sean McIntyre, assistant research professor in the Applied Research Lab, and Rob Campbell, associate professor of mechanical engineering

Student: Sean Gauntt, doctoral candidate in mechanical engineering

Sponsor: U.S. Army, U.S. Navy and NASA (via PSU VLRCOE award)

Summary: The hybrid gear project focuses on decreasing rotorcraft vehicle weight by decreasing the weight of the drive system through integration of composite materials into gear design. Current work for the normal operation aspect of the project is focused on developing an optimization technique for a sinusoidal interlock design of a 3.5" hybrid spur gear—the loss-of-lubrication aspect is a separate, but related, student effort. The design consists of a metallic outer ring—to support high contact stress—bonded to a composite inner web for weight reduction (see image below). The composite-steel interface is defined by a sinusoidal interlock. An initial topology optimization was performed and reported last year using two objective functions—mass and shear traction on the metal-composite interface under static loading conditions. The optimization was expanded to minimize tooth bending with the intent of reducing gear transmission error and hence noise and vibration. Borg MOEA, a multi-objective evolutionary algorithm developed at Penn State, and an in-house finite element solver are used to generate Pareto-optimal solutions to the problem. Three of the optimal designs are analyzed in the geartrain modeling software Romax to assess gear transmission error of the hybrid gears relative to the all-metallic gear. Techniques developed and demonstrated for the 3.5" spur gear will be applied to a larger, more complex gear that offers greater potential for overall weight savings.

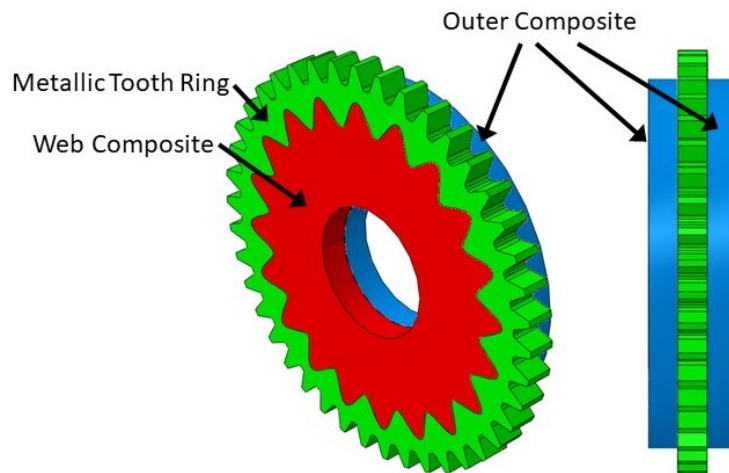

Vibration and noise control using embedded acoustic black holes

PIs: Ed Smith, professor of aerospace engineering, and Steve Conlon, research professor in the Applied Research Lab

Student: Yu Xiong, doctoral candidate in aerospace engineering

Sponsor: Penn State Department of Aerospace Engineering and Vertical Lift Research Center of Excellence

Summary: An analytical model, using a Transfer Matrix Method and Fourier Acoustics Approach, was developed to assess the vibroacoustic characteristics of Acoustic Black Hole (ABH) beam structures. The model was used to conduct a parametric study investigating the relation of three important ABH parameters: size, taper power, and truncation thickness. An optimal thickness of an added damping layer and the potential benefits of employing ABH tuning masses were also assessed. The results are being used to design more complex ABH plate structures and developed ABH design metrics for ABH applications to control the noise and vibration of lightweight structures.

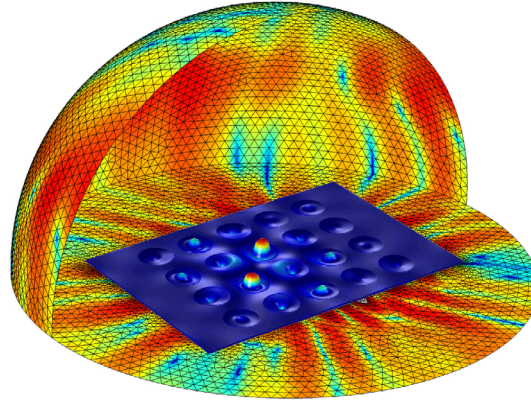

Carbon nanotube loudspeaker technology development

PIs: Tim Brungart, research professor in acoustics, and Ben Beck, assistant research professor in the Applied Research Lab

Student: James Chatterley

Sponsor: Joint Non-lethal Weapons Directorate

Summary: Development of a coupled electrical, thermodynamic, fluid dynamic, and mechanical model of carbon nanotube (CNT) loudspeaker sound generation to: Explore the pertinent multiphysics interactions leading to CNT sound generation; Identify means to increase CNT sound generation efficiency, sound pressure output, and power handling; Identify technology limitations focusing on CNT sound generation efficiency including fundamental physical limits to the transduction efficiency and major contributors to system inefficiencies; Explore the utility of signal processing as a means of increasing the CNT sound generation efficiency; Identify CNT forest and film properties that could be tailored to increase sound generation efficiency, power handling, and robustness. Additionally, we will perform benchtop testing with CNT film samples to complement and begin verifying the multiphysics modeling and use of signal processing to increase sound generation efficiency.

Extreme value statistics of flow-induced noise and vibration

PIs: Stephen Conlon, research professor in the Applied Research Lab, and Manton Guers, assistant research professor in the Applied Research Lab

Student: Connor McCluskey, doctoral candidate in acoustics

Sponsor: NAVSEA 073R

Summary: Flow-induced noise and vibration produce cyclic loading on structures such as wind turbines and vehicle control surfaces. Since the flow excitation is often random in nature, infrequent large amplitude loads are expected to occur in these applications. These large outlier loads ultimately decrease the fatigue performance of these structures. The goal of this work is to develop the theory for predicting the flow-induced structural response to extreme events and the resulting impact on maximum design loads and cyclic fatigue. Improved methodologies for determining relevant design loads are being investigated to account for these rare events. To accomplish this, extreme value statistics are applied to flow-induced vibration response data. Future work will examine single degree of freedom and finite element models for performing parametric studies and predicting stress-strain cycles.

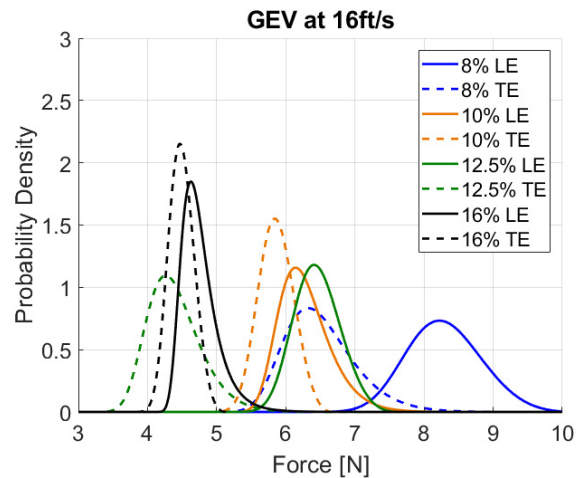

Comparison of airfoil leading edge (LE) and trailing edge (TE) lift extreme value distributions for separate thicknesses

Digital image correlation for vibration measurements

PI: Tyler Dare, assistant research professor in the Applied Research Lab

Student: Sean Collier, doctoral candidate in acoustics

Sponsor: Walker Graduate Assistantship Program

Summary: Motion magnification is a video processing technique in which sub-pixel motions are made to appear large. Recent advances in video processing algorithms—including the Reisz pyramid and the Complex Steerable Pyramid—have been implemented to magnify vibration within a given frequency band. However, these methods can fail when combined with bulk motion of the vibrating structure. For example, the vibration of a fan blade can be obscured by the rigid body rotation of the fan. This research involves developing techniques to separate large (super-pixel) motion from vibration and investigating whether high-speed video with motion magnification can be used as a robust, non-contact vibration measurement technique for a wide variety of vibrating structures.

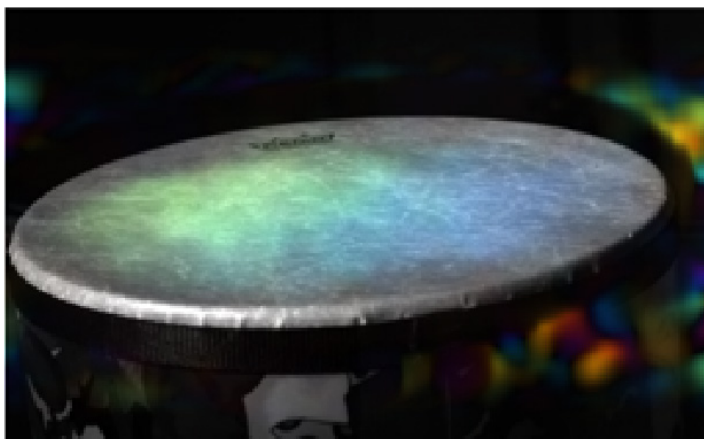

Mode shape extracted from high-speed camera data of acoustically-excited vibrating drum head. Color indicates phase of vibrating regions.

Large chiller noise and vibration

PIs: Steve Hambric, research professor in acoustics, and Tim Brungart, research professor in acoustics

Student: Stephen Wells, doctoral candidate in acoustics

Sponsor: UTC Building and Information Systems (Carrier)

Summary: Noise and vibration was measured on a 1600-ton capacity water-cooled industrial chiller

that is comprised of a centrifugal compressor mounted on top of an evaporator in a side-by-side condenser/evaporator system. An evaluation of the chiller components with an acoustic camera indicates that the dominant radiation mechanism of these tones results from the coupling of the compressor-induced tones with the low order shell modes of the compressor discharge pipe, which is comprised of a horizontal section attached to the compressor discharge, a 90-degree elbow, and a vertical section connected to the condenser. The structural modes of interest are above the coincidence frequencies of the condenser shell and compressor discharge pipe structures, respectively, resulting in efficient sound radiation. A hybrid Experimental/Finite Element/Statistical Energy Analysis model has been constructed to simulate the chiller vibration and sound.

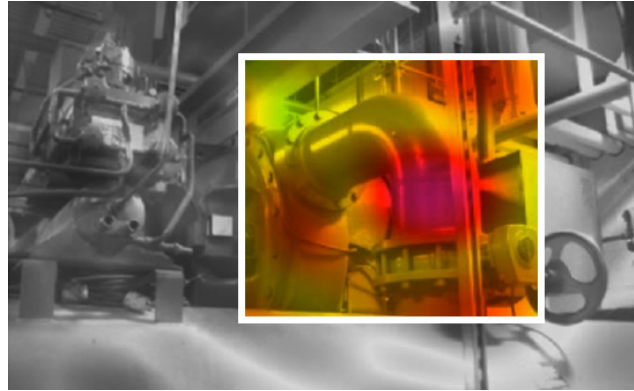

Power transmission efficiency between coupled structures

PIs: Kyle Myers, assistant research professor in the Applied Research Lab, and Robert Campbell, associate professor in the Applied Research Lab

Student: Jonathan Young, doctoral candidate in mechanical engineering

Summary: The transmission of structure-borne sound between a source and receiver structure is a valuable quantity to know when designing quiet structures. Through the use of a dual domain decomposition technique, known as the Lagrange Multiplier Frequency Based Substructuring method, and transmission characteristics of the source structure, the power transmission efficiency between a source and receiver structure can be determined. This allows for transmission efficiency to be calculated on a degree-of-freedom and modal basis, allowing the analyst to determine the dominant directions and modes of power transmission.

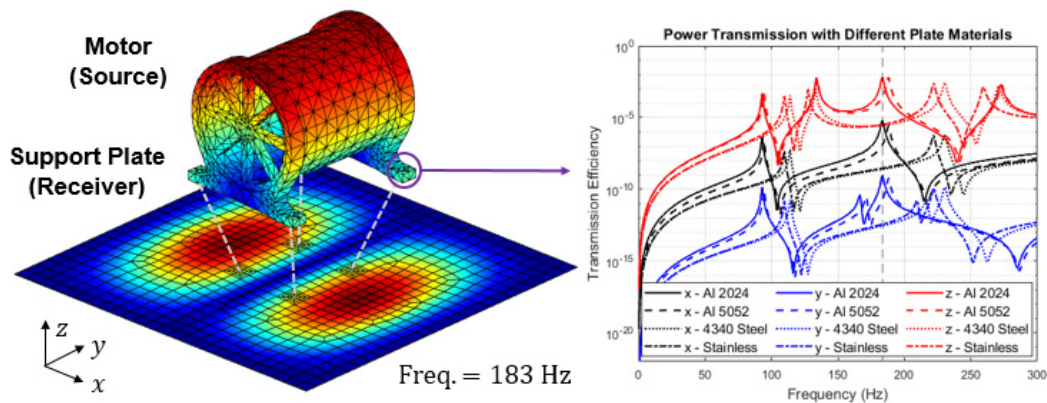

Optimization of acoustic black hole design for improved structural acoustics

PI: Micah Shepherd, assistant research professor in acoustics

Student: Cameron McCormick, doctoral candidate in acoustics

Sponsor: Applied Research Laboratory Walker Fellowship

Summary: Arrays of Acoustic Black Holes (ABHs) have the potential to significantly reduce structural vibration and radiated sound. However, the optimal hole profiles, sizes, damping, and spacing are difficult to determine. An automated global optimization procedure and high-performance parallel computing methods are applied to vibroacoustic problems to demonstrate the optimal design of ABHs.

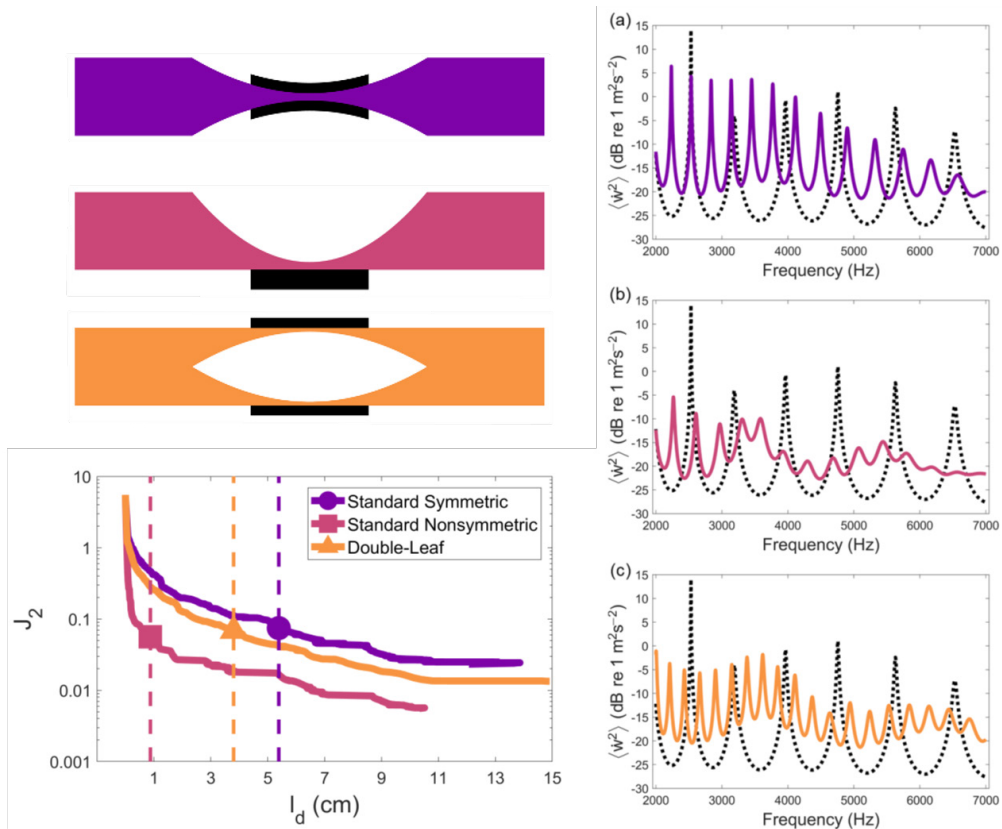

The styles of embedded ABHs were optimized to simultaneously minimize mass and vibration. The Pareto fronts illustrate the trade-off which occurs between reducing mass and reducing vibration levels.

Nonlinear structural joint dynamics

PIs: Micah Shepherd, assistant research professor in acoustics, and Steve Hambric, research professor in acoustics

Student: Trevor Jerome, doctoral candidate in acoustics

Sponsor: NAVSEA 073R

Summary: The dynamics of structural joints, despite much research, remain poorly understood. A rigorous treatment of two plates with a bolted L-joint is underway—including ultrasonic scanning of the contact pressures on the faying surface, non-contact acoustic excitation of the structure and analysis of the non-linearities in the response time histories, and eventually simplified finite element modeling of the joint stiffness and damping.

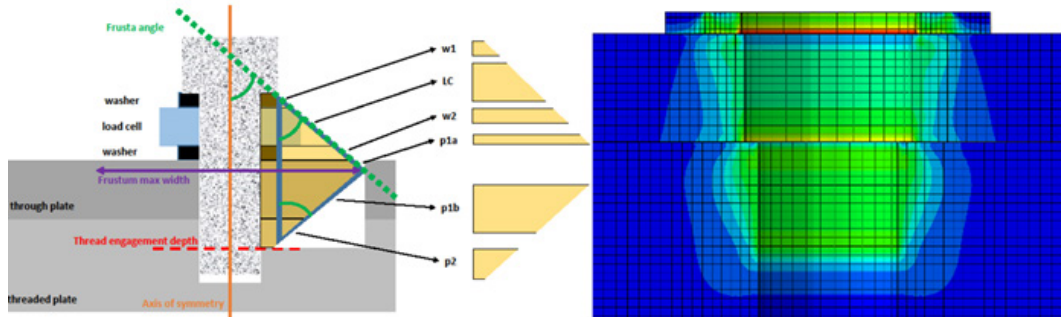

The pressure underneath a bolt is often approximated using frusta theory but detailed finite element models illustrate the shortcomings of this method.

Measuring plate vibration using deflectometry with add-on reflective material

PIs: Micah Shepherd, assistant research professor in acoustics, and Jeff Harris, assistant research professor in the Applied Research Lab

Students: Gary Rhoades, graduate student in acoustics

Sponsor info is missing here

Summary: Deflectometry is a full-field optical method which utilizes the slope fields on the surface of a planar object to track deformations. The use of a high-speed camera gives the ability to measure all points on the surface instantaneously and with high spatial resolution, providing more knowledge on how structures react to transient excitations. The reflected grid method is being used, which relies on specular reflections to create amplifications of the measured deformations in the test plate. A set of experiments are being conducted to test the vibration of a flat plate excited by an automatic force hammer. A collection of adhesive tapes, films, and spray were applied to the test object in order to increase the reflectivity of the plate.

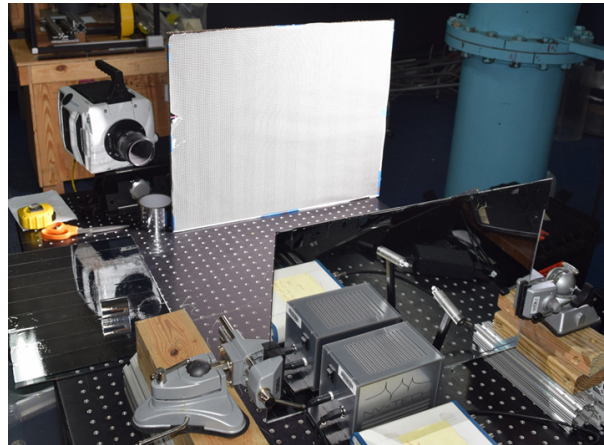

Uncertainty quantification in flow-induced vibro-acoustic simulations

PIs: Andrew Wixom, assistant research professor in the Applied Research Lab, and Sheri Martinelli, assistant research professor in the Applied Research Lab

Student: Gage Walters, doctoral candidate in mechanical engineering

Sponsor: NAVSEA 073R

Summary: Significant effort has been invested in applying uncertainty quantification (UQ) techniques to engineering and physical models to understand how input variability affects these models' dynamic response. This work explores the application of one of these UQ techniques, generalized polynomial chaos (GPC), to understand the uncertainty in the output response of fluid forcing on structures. In particular, non-intrusive methods (i.e. "blackbox" methods) for computing GPC surrogate models is studied here as they permit reuse of existing computational codes and capture statistical information at significantly fewer evaluations of the deterministic code compared to random sampling methods such as Monte Carlo. Throughout this work, problems involving sound generated by flow-induced vibrations have been used as demonstrations of the method, including cases such as turbulent boundary flow over a flexible flat plate and turbulent inflow to a hydrofoil. Key developments of this work to date include: a flexible in-house framework for applying GPC to arbitrary blackbox models, an optimization based procedure for generating high dimensional quadrature rules necessary to calculate GPC surrogate models, and most recently, a new technique for reconstructing and visualizing the output probability density function (PDF) for multidimensional input uncertainty.

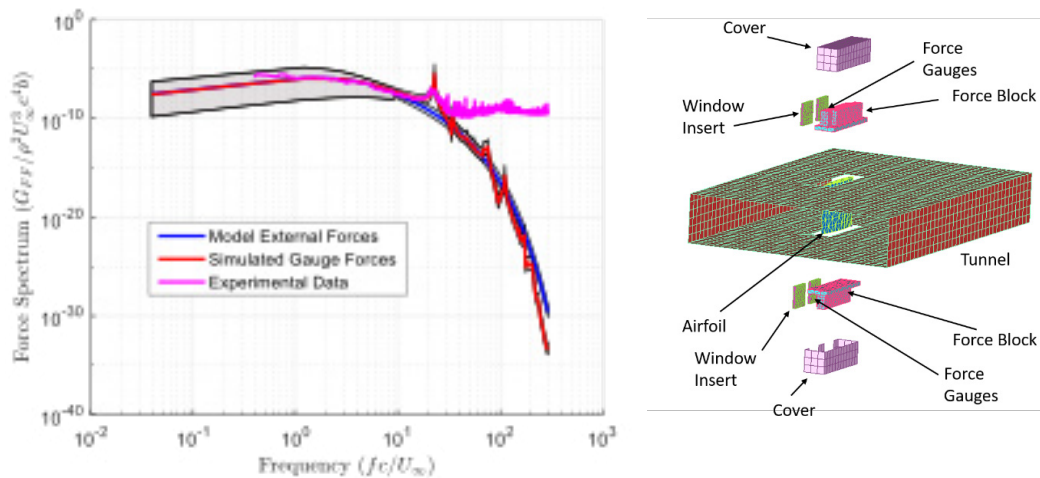

Uncertainty introduced into the forcing and structural parameters of a fluid-structure interaction model designed to calculate the turbulence ingestion response of a hydrofoil. Finite element model of the hydrofoil in a water tunnel experiment (left) and the forced response of the plate with uncertainty (right). Note the shaded region is where values of the response can occur with the given input uncertainty and that the experimental data falls inside this region except in the noise floor of the measurement.

Vibrational analysis of ash and composite hurlers

PI: Dan Russell, teaching professor of acoustics and distance education coordinator

Student: Kathryn Krainc, graduate student in acoustics

Summary: Hurling is a stick-ball sport native to Ireland. An experimental modal analysis was used to extract frequencies, mode shapes, and damping rates for a collection of ash wood (four different manufacturers) and plastic/composite materials (six different manufacturers) in an attempt to consider the perception of composite hurlers as a replacement for ash in terms of expected feel. Vibrational mode shapes were similar for all sticks, but frequencies and damping rates showed a considerable spread. Some composite sticks have similar frequencies to wood—often with higher damping rates—suggesting these composite sticks would feel and perform just like ash. Plastic sticks have frequencies and damping rates very different from ash, suggesting that they would not at all feel like ash. Some composite sticks were found to have the potential for a trampoline effect, though current sticks are not tuned to take advantage of this performance enhancement.

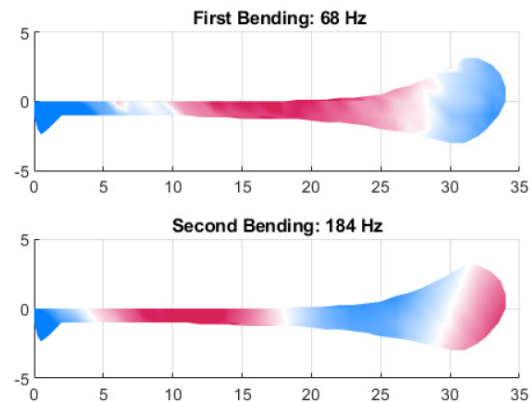
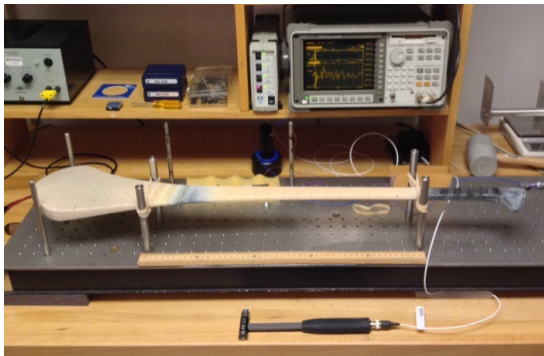

Determining the location and influence of cello soundposts

PIs: Micah Shepherd, assistant research professor in acoustics, and Tom Blanford, assistant research professor in the Applied Research Lab

Students: Eric Rokni, doctoral candidate in acoustics, and Molly Smallcomb, doctoral candidate in acoustics

Summary: The soundpost in a cello plays an important role in the dynamics of the body and ultimately the sound produced by the instrument. A series of studies is being performed to localize the soundpost and determine its effect on carved and laminate cellos.

Systems and Structures Health Management



Group Leader: Cliff Lissenden
Professor of engineering science and mechanics



Group Leader: Karl Reichard
Associate research professor of acoustics

Group Summary

The mission of the Systems and Structures Health Management Technical Group is to develop new methodologies and technologies to manage the life cycle of systems and structures. This includes the full range of material state awareness, health and usage monitoring, and condition-based maintenance, to support both autonomic and conventional operations with logistics informed by reliable useful life prediction. The

underlying goal of the group is to maximize safety, minimize life cycle cost, and increase capability. Key areas being investigated include sensor systems, signal processing, pattern recognition, reasoning techniques, and modeling of damage progression to failure.

Below are some highlights of this group's recent work:

Nonlinear laser ultrasonics for reduced variability in additive manufacturing

PIs: Cliff Lissenden, professor of engineering science and mechanics, and Ted Reutzel, associate professor of engineering science and mechanics

Student: Gerald Boddie, doctoral candidate in engineering science and mechanics

Sponsor: Penn State Vertical Lift Research Center of Excellence (U.S. Army, U.S. Navy, NASA)

Summary: High reliability and low variability is crucial for flight critical rotorcraft parts, but additive manufacturing (AM) processes, despite providing revolutionary capabilities, have complex physics that typically result in some level of material variability. We are investigating laser generated Rayleigh waves to interrogate the current surface layers in an AM build in-situ in order to provide feedback for process control and stop the build process if defects are detected.

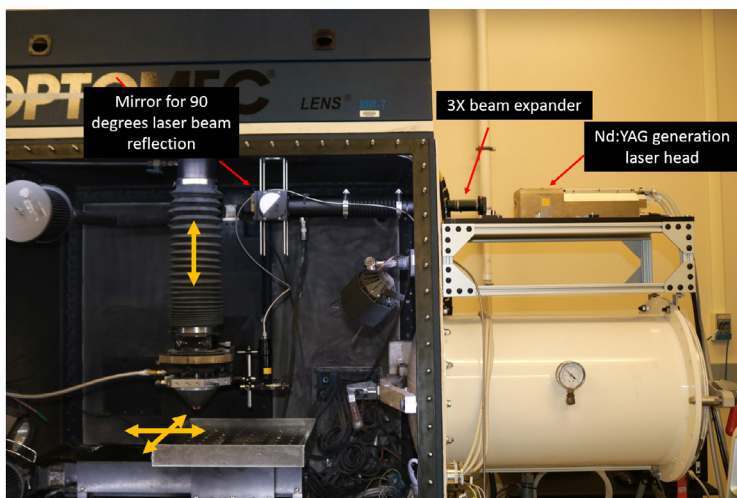

Laser ultrasound system integrated into the directed energy deposition chamber at Penn State's CIMP-3D.

Mixing elastic waves to nondestructively characterize microstructure during additive manufacturing of metals

PIs: Cliff Lissenden, professor of engineering science and mechanics, and Abdalla Nassar, associate research professor in the Applied Research Lab

Student: Chaitanya Bakre, doctoral candidate in engineering science and mechanics

Sponsor: National Science Foundation

Summary: The complex physics involved in additive manufacturing can result in variable material microstructures that therefore have variable strength properties. This investigation assesses whether the mixing of elastic waves (i.e., Rayleigh waves as shown below) can provide in-situ information during processing about the material's microstructure based on waves generated at the sum and difference frequencies by the laser-generated Rayleigh waves.

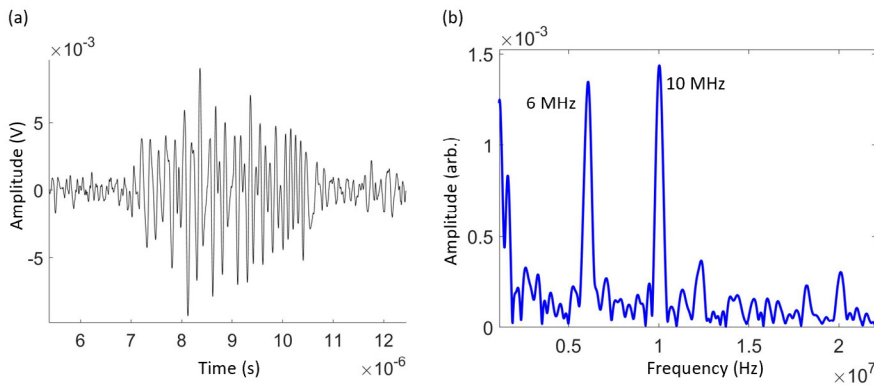

A-scan (amplitude as a function time) of the wave packet generated by a laser beam passed through two slit mask arrays having spacings of 0.5 and 0.3 mm, resulting in the Rayleigh wave frequencies of 6 and 10 MHz shown in the frequency spectrum of the A-scan.

NDT of fracture toughness for pipeline steels (SBIR)

PIs: Cody Borigo, Guidedwave; Russell Love, Guidedwave; Cliff Lissenden, professor of engineering science and mechanics; and Parisa Shokouhi, associate professor of engineering science and mechanics

Student: Anurup Guha

Sponsor: U.S. Department of Transportation

Summary: Knowledge of the fracture toughness of pipeline steel is extremely valuable to the pipeline operators. However, nondestructive methods to measure it in the field do not exist. We are investigating the use of nonlinear Rayleigh wave propagation for nondestructive testing (NDT) of pipeline steels. Tempering of steel transforms the microstructure, which creates a wide range of fracture toughness values. Likewise, the microstructure also distorts ultrasonic waves. We are investigating the connection between ultrasonic wave distortion and the fracture toughness, maximizing distortion as a function of microstructure, and designing the measurement techniques for field use.

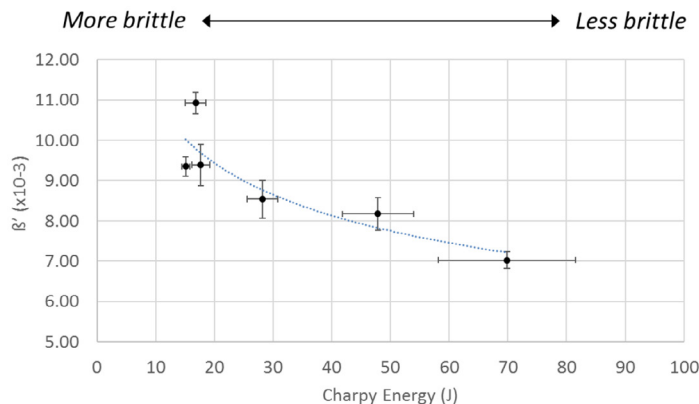

Measured relative ultrasonic nonlinearity parameter as a function of absorbed energy from Charpy impact tests of AISI 4130 steel.

Prediction of stress corrosion cracking by nonlinear ultrasonic guided wave technology (SBIR)

PIs: Cody Borigo, Guidedwave; Steve Owens, Guidedwave; Jason Philtron, Guidedwave; and Cliff Lissenden, professor of engineering science and mechanics
Any students?

Sponsor: U.S. Air Force

Summary: Stress corrosion cracking is both an insidious damage mode and difficult to detect. We are investigating the use of nonlinear Rayleigh waves to detect the extent of stress corrosion cracking at a surface. A large population of samples containing various degrees of (i) stress corrosion cracking and (ii) corrosion due to increasing exposure times are being ultrasonically tested in order to calibrate the ultrasonic nonlinearity with the extent of material degradation.

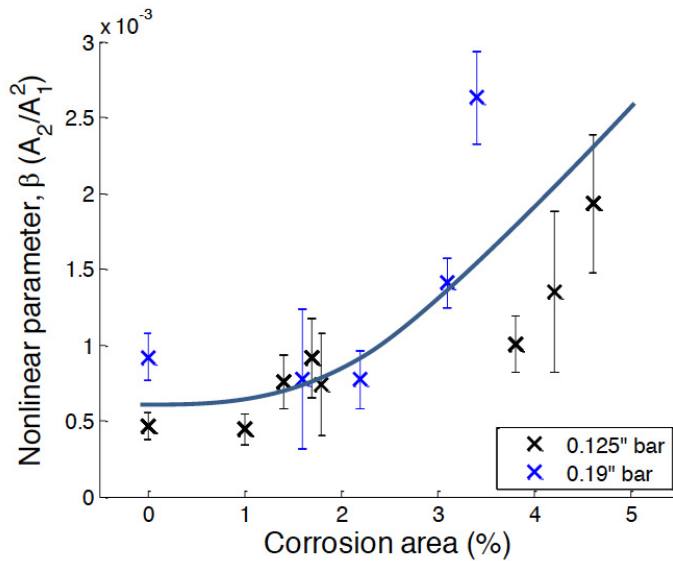

Preliminary results indicate that the relative nonlinearity parameter increases with the severity of stress corrosion cracking in aluminum alloy.

Ultrasonic guided waves as a diagnostic tool to evaluate osteoporosis and fragility fractures

PIs: Michael Aynardi, Hershey Medical Center; Greg Lewis, Hershey Medical Center; Cliff Lissenden, professor of engineering science and mechanics; and Parisa Shokouhi, associate professor of engineering science and mechanics

Student: Anurup Guha, doctoral candidate in engineering science and mechanics

Summary: Ultrasonic guided waves in long human bones have strong potential as a diagnostic tool to assist health care professionals in managing the fracture healing process and quantifying osteoporosis-related frailty. However, long human bones are complex waveguides that are anisotropic, attenuative, and have an irregular cross-section that varies significantly along the length of the bone. We are investigating wave propagation using semi-analytical, frequency-domain, and time-domain finite element analyses. In addition, we are developing appropriate techniques for noninvasive diagnosis of bone health.

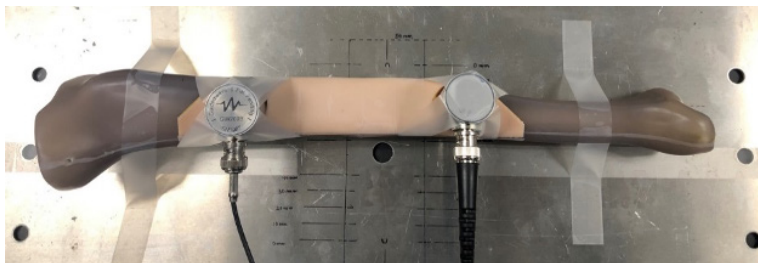

Shear transducers are able to generate guided waves through a synthetic skin layer into a synthetic tibia.

A meta-surface to control surface wave propagation

PIs: Parisa Shokouhi, associate professor of engineering science and mechanics; Mary Frecker, professor of mechanical engineering; and Cliff Lissenden, professor of engineering science and mechanics

Student: Daniel Giraldo Guzman, doctoral student in mechanical engineering

Sponsor: National Science Foundation

Summary: Our research objective is to control the motion of Rayleigh surface waves through modifying the surface along which the waves propagate—i.e., by purposefully changing the boundary conditions (BCs) on the surface in order to promote desirable reflections and mode conversions. One way to impose the necessary BCs for a given range of frequencies is to place an assembly of resonators on the surface at sub-wavelength spacing. Such resonant meta-surfaces are typically designed through a parametric study of the dispersion curves and tuning the resonance frequencies for a periodic unit cell. Our proposed method takes the view that BCs are the key to providing the desired control. This new approach suggests a systematic strategy for creating a meta-surface, a departure from the commonly used parametric process. The fundamental knowledge gained in this research will have potential applications across length scales. Examples include, but are not limited to, design of next-generation miniature surface acoustic wave (SAW) filters, narrow-band actuators and sensors, vibration isolating barriers, as well as seismic and explosive shields for vulnerable structures or even towns.

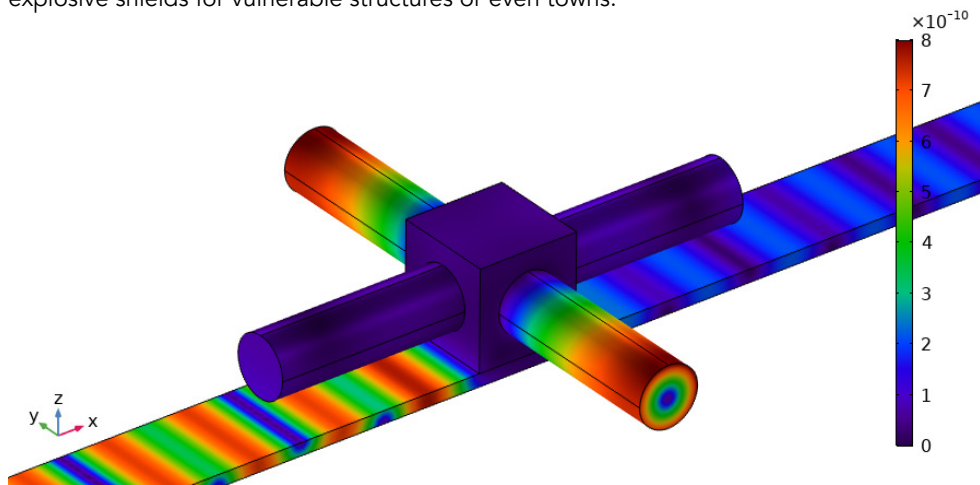

The boundary conditions imposed on the surface of a plate waveguide by a 'four-arm' resonator reflects the incoming S0 wave mode.

Linear and nonlinear resonance ultrasonic spectroscopy for real-time process control of additively manufactured parts

PIs: Parisa Shokouhi, associate professor of engineering science and mechanics, and Jacques Rivière, assistant professor of engineering science and mechanics

Students: Prabhakaran Manogharan, doctoral candidate in engineering science and mechanics, and Evan Bozek, undergraduate student in engineering science

Sponsor: American Society for Nondestructive Testing (ASNT)

Summary: This project proposes a novel approach based on linear and nonlinear resonance ultrasonic spectroscopy (N/RUS). One of the advantages of this approach is that it can be used to inspect parts of irregular shapes, complex geometries, and compositions. Furthermore, the test set up is relatively simple; the excitation source will be placed under the build plate, and the response will be recorded on the part top surface using a non-contact laser Doppler vibrometer. Finally, using a combined linear and nonlinear approach, a variety of defects ranging from pores to micro-crack like flaws can be detected. Our proposed work involves testing a set of specimens of complex geometry with a range of built-in defects to demonstrate the feasibility of the approach. This will enable us to report the method detectability thresholds with respect to different types of defects. The proposed approach will be used to inspect samples at various stages of manufacturing in order to find the optimum test procedure for in-situ real-time inspection. The project results will be used to develop a test protocol for real-time process control of additively manufactured parts.

Nonlinear Resonance Ultrasound Spectroscopy

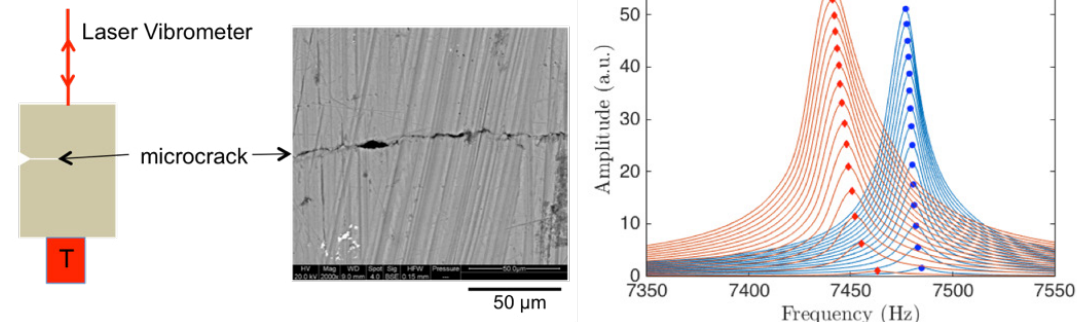

Illustration of Nonlinear Resonance Ultrasound Spectroscopy (NRUS) applied to one intact and one cracked sample. An SEM image shows a small portion of the micro-crack, which is invisible to the eye. Note how the resonance frequency shifts downward with excitation amplitude for the cracked sample.

A wave physics-informed deep learning framework for acoustic data

PIs: Parisa Shokouhi, associate professor of engineering science and mechanics, and Daniel Kifer, associate professor of computer science

Sponsor: Penn State College of Engineering Multidisciplinary Seed Grant

Summary: The goal of this collaboration is to develop a framework for integrating complex wave physics into machine learning prediction models that use acoustic sensory data. Acoustic sensor output signals are solutions to the governing wave equation and are rich in information about the medium. Despite their ubiquitous use, the signals are often underutilized—reduced to a few hand-crafted features, the rest being discarded. Conversely, data-driven models often discount the physical principles. We hypothesize that utilizing the entirety of the signals, while respecting known physical relations, will result in improved adaptable predictive models. We will focus on three large, previously-collected laboratory datasets. The outcome will be a framework for wave physics-guided predictive modeling.

Resonance ultrasonic spectroscopy (RUS) for quality control/assurance of 3D-printed components

PIs: Parisa Shokouhi, associate professor of engineering science and mechanics; Jacques Rivière, assistant professor of engineering science and mechanics; and Andrea Arguelles, assistant professor of engineering science and mechanics

Student: Samantha McGuigan, graduate student in engineering science and mechanics

Sponsor: National Institute of Standards and Technology (NIST)

Summary: In this project, we use linear resonance ultrasonic spectroscopy (RUS) to inspect parts of irregular shapes, complex geometries, and compositions. Our research methods include numerical simulations and controlled laboratory testing. The testing is done on a set of additively manufactured specimens—made available to us by NIST—of complex geometry with a range of built-in defects to demonstrate the feasibility of the approach. One set of specimens are complex lattice structures with different numbers of missing struts (shown in the figure below). Our goal is to find the detectability threshold of RUS in detecting the number of missing struts. We will devise an experimental protocol for RUS applied to complex-shaped additively manufactured samples.



(a)

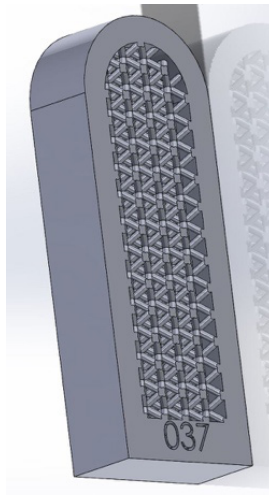

(b)

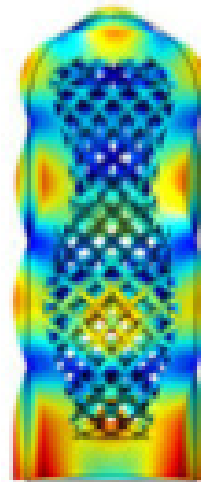

(a) Resonance Ultrasonic Spectroscopy (RUS) testing of a complex lattice structure. We test lattices with different number of missing struts. (b) Numerical simulations are performed to help interpret the recorded RUS spectra.

Coupled assessment of seismic, hydraulic and frictional properties of fractured rock to illuminate fundamental process governing energy production and waste storage

PIs: Parisa Shokouhi, associate professor of engineering science and mechanics; Chris Marone, professor of geosciences; Derek Elsworth, professor of energy and geo-environmental systems; Jacques Rivière, assistant professor of engineering science and mechanics; and Paul Johnson, Los Alamos National Laboratory

Students: Clay Wood, doctoral candidate in geosciences, Prabhakaran Manogharan, doctoral candidate in engineering science and mechanics; and Jing Jin, former Penn State student

Postdoc: Sheng Zhi

Sponsor: Department of Energy (DOE) – Office of Basic Energy Science (BES)

Summary: We conduct a series of laboratory experiments designed to simulate local effective stress field fluctuation and its influence on the evolution of permeability and dynamic stiffness in fractured samples of Westerly Granite. L-shaped samples are loaded with tri-axial stresses and fractured in-situ. The fracture is subsequently sheared in two 4-millimeter steps. Oscillatory changes in the local effective stress field are imposed through application of normal stress or pore water pressure oscillations with varying amplitudes and frequencies. Active ultrasonic data—ultrasonic waves transmitted across the fracture—is used to monitor the evolution of wave velocity and attenuation before, during, and after dynamic stressing. Throughout the experiment, the evolution of permeability is concurrently measured to determine the relationship between fracture permeability and nonlinear elastodynamic properties—stress-dependency of wave velocity and attenuation. Our results to date indicate that relative changes in wave velocity and permeability, due to both normal stress and pore pressure oscillations, are correlated, such that larger drops in wave velocity correspond to larger increases in permeability. Shearing of the fracture reduces the nonlinearity measured during normal stress oscillations for both rock samples. After shearing, the oscillations become generally less effective in enhancing the fracture permeability.

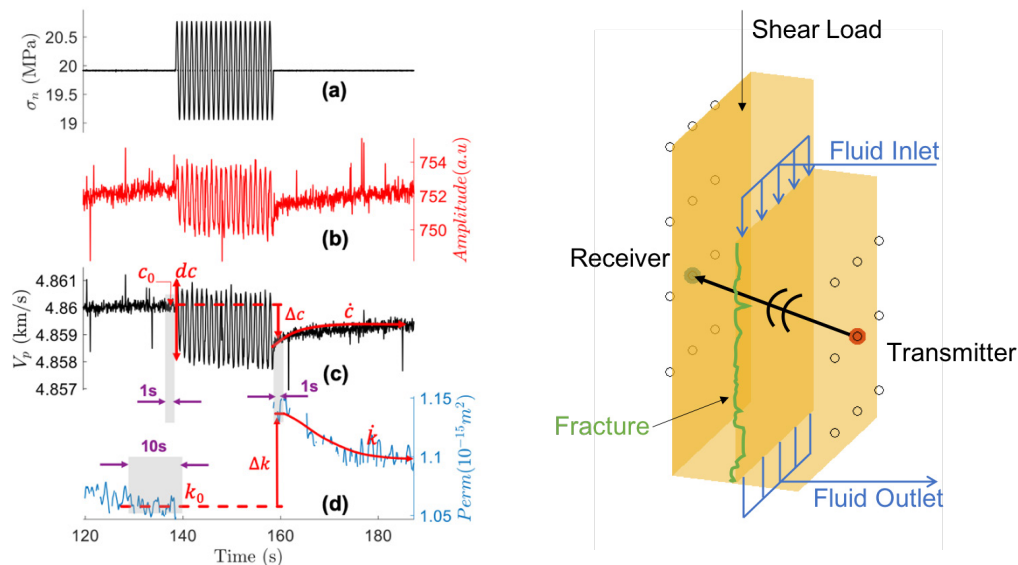

Typical response of fractured rock to stress perturbation: (a) imposed normal stress oscillations, the resulting evolutions of (b) ultrasonic wave amplitude, (c) velocity and (d) permeability with time.

Rapid automation technology evaluation – health monitoring of automated drilling systems (ADS)

PIs: Jeff Banks, research and development engineer in the Applied Research Lab, and Matt Rigdon, research and development in the Applied Research Lab

Students: Nicholas Carder, graduate student in acoustics, and Trent Furlong, graduate student in acoustics

Sponsor: U.S. Navy Manufacturing Technology Program

Summary: The F-35 center-fuselage is fabricated using a highly automated Department of Defense aircraft assembly line called the Integrated Assembly Line (IAL). Northrop Grumman Aerospace Systems (NGAS) has developed and implemented several robotic assembly systems to support manufacturing activities for the award-winning F-35 IAL, such as the Automated Drilling Systems (ADS). Key pieces of automation such as the ADS are required to operate on a repeatable basis to realize committed production schedules and cost targets. Automation engineers, production operations, and facilities engineers require a predictive machinery failure indication capability on critical automation assets to proactively manage these systems in order to guarantee their capacity to manufacture quality parts within the program production intervals. The figure below shows a similar system used in the production of civilian passenger aircraft. The ADS has been instrumented with accelerometers and current sensors. This data will be used to assess the wear state of the cutting tools and to detect bearing and gear faults in the cutting head and the robotic positioning system. The team is currently collecting data on representative numerically controlled machines at Penn State and will continue to collect data at the F-35 manufacturing facility this summer.



Robotic drilling systems used in the production of civilian aircraft fuselage.

Hybrid prognostics at the tactical edge

PIs: Karl Reichard, associate research professor in acoustics, and Jeff Banks, research and development engineer in the Applied Research Lab

Students: Daniel Watson, doctoral candidate in acoustics

Sponsor: Office of Naval Research

Summary: The goal of this project is to develop hybrid approaches to prognostic health management, which combine traditional physics and engineering-based models of machinery health and damage progression with machine learning and artificial intelligence-based techniques. Many modern systems such as aircraft, ships, trucks, and manufacturing systems collect operational and performance data, but typically lack data from sensors specifically chosen to monitor critical faults or failure modes. Some systems, such as helicopters, do have onboard health and usage monitoring systems to collect health-related sensor data as well as general state data.

The research program is concentrating on three areas:

- Collection of platform performance and state data from ground vehicles, helicopters, and ships
- Development of machine learning health assessment models
- Development of hybrid prognostic architectures to incorporate physical and engineering models in the machine learning process

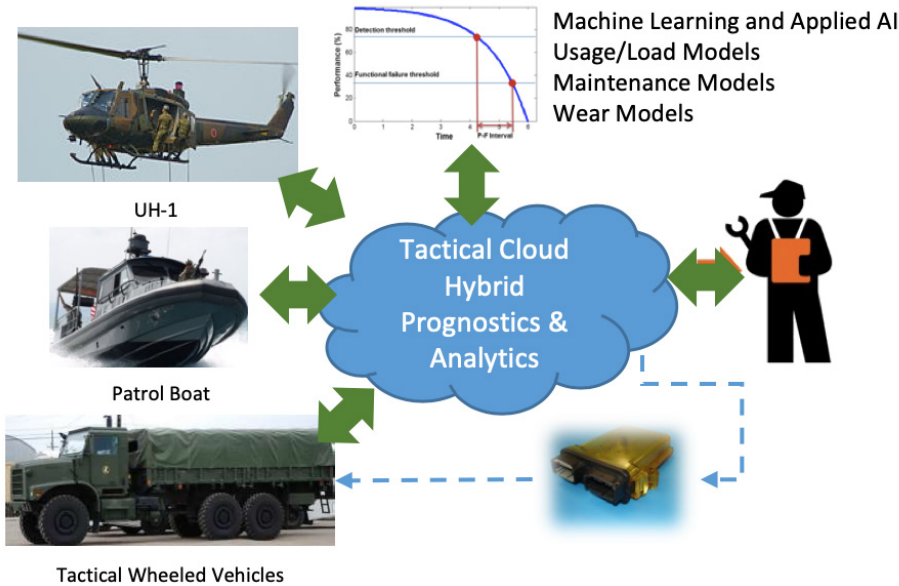

Hybrid prognostics combines machine learning from platform performance and sensor data with physics and engineering models to improve predictive capability

A computationally efficient nonlinear Kalman filter for online system identification and performance prediction

PIs: Kostas Papakonstantinou, assistant professor of civil engineering, and Gordon Warn, associate professor of civil engineering

Student: Mariyam Amir, doctoral candidate in civil engineering

Sponsors: National Science Foundation and Penn State

Summary: System identification in the form of dynamic states and parameters inference through available measurements plays an important role for condition assessment, performance prediction, and adaptive control, among others. One of the most popular and powerful online techniques, applicable to nonlinear systems, is the sampling-based Unscented Kalman Filter (UKF). The computational efficiency of any sampling-based filtering process is mainly dependent on the required number of samples, often called sigma points, at each time step, in order to effectively quantify statistical properties of related states and parameters. Reducing the needed sample size is therefore important for any application and particularly relevant in many engineering cases when the underlying model is high dimensional and computationally expensive. Hence, the present work introduces a novel Scaled Spherical Simplex Filter (S3F), requiring for a n -dimensional nonlinear system, a reduced $n+2$ number of sigma points, in contrast to the typical $2n+1$ UKF scheme, while achieving the same level of accuracy in all general cases. An illustrative comparison of the S3F and UKF is shown in Figure 1 for a three-dimensional normal space. The S3F can be therefore applied in all applications where UKF is used—e.g. structural health monitoring, vibration control, simultaneous localization and mapping (SLAM), robotics, navigation, target tracking, etc.—while achieving in all cases an equivalent UKF accuracy for all distribution types, albeit at a ~50% reduced computational effort. Figure 2 provides a brief indicative numerical comparison of the two filters for a nonlinear dynamic system.

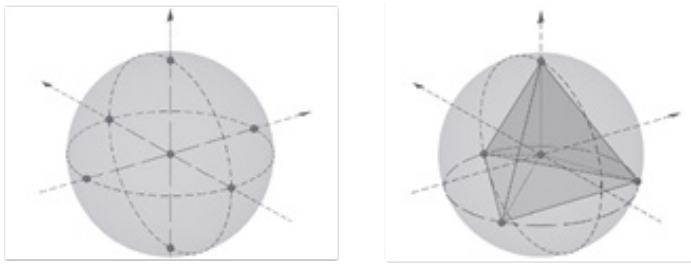

Fig. 1: Sigma points locations on a 3-dimensional normal space, for both UKF (left) and S3F (right) filters.

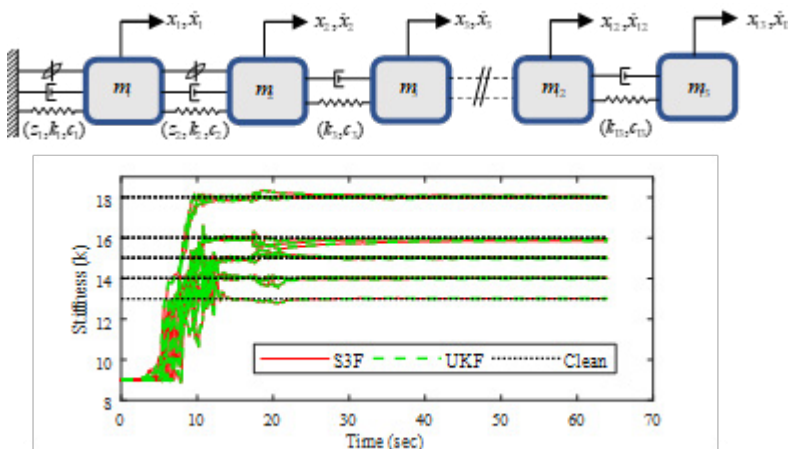
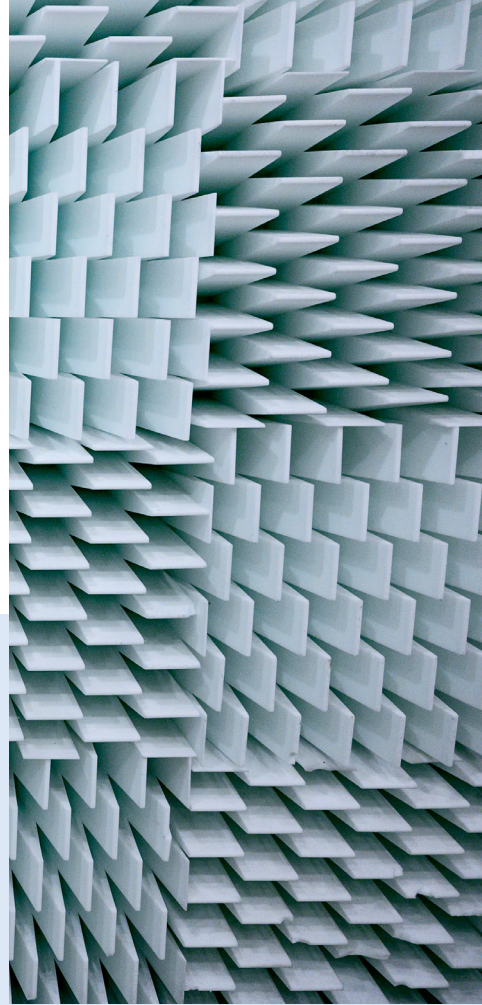
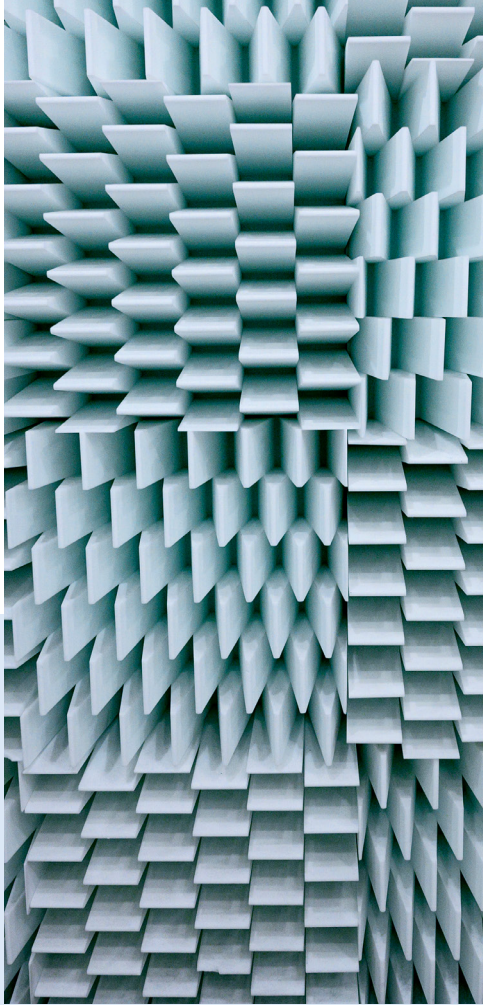

Fig. 2: Parameters estimation of a nonlinear hysteretic system.



CAV Contact Info

Stephen A. Hambric

Research professor in acoustics
sah19@psu.edu

Clifford Lissenden

*Professor of engineering science
and mechanics*
lissenden@psu.edu

www.cav.psu.edu

Diane Bierly

*Editorial assistant in engineering science
and mechanics*
302 Earth and Engineering Sciences Building
814-863-6491 // dkb11@psu.edu

Kelly Driftmier

Workshop and corporate sponsor liaison
225 Penn State Conference Center
814-865-9202 // kmd5315@psu.edu